



## FXM2-S Metering Pump



IIoT  
ready

### Features

- Only the tube is in contact with the process medium
- Self-priming (up to 90 % of full vacuum)
- Fully reversible operation
- Dry run capability
- Accurate metering throughout the whole operating range
- Remote start/stop
- Basic logic control
- Ready for online access through Flowrox Malibu™ platform (IIoT)
- Serviceable rotor construction for ease of maintenance
- Automatic identification of supply voltage
- Field switchable power cord - no need to open pump housing
- Available with flow verification switch
- Digital touchpad adjustment - precise and reliable
- 3,5" backlit high resolution display
- Display languages: English, German, Spanish, French, Finnish
- Security: programmable 4-digit password

### Materials of Construction

#### Primary pump wetted components:

Pump tube elements	Norprene® (for chemicals) or Tygothane® (for oils and fats) or Tygon lined Norprene® (acids). Adapter fittings: PVDF
--------------------	---

#### Accessories wetted components:

Suction tubing	Clear PVC
Suction strainer	Natural polypropylene
Discharge tubing	Natural polyethylene (LLDPE)
Injection fitting with check valve	Body & insert: PVDF

#### Non-wetted components:

Pump head	PBT GF30
Housing	Powder coated aluminium
Pump head cover	Clear acrylic
Cover screws	300 SS, polypropylene caps
Roller assembly	Rotor: PBT GF30 Rollers: POM Roller bearings: ball bearing
Motor shaft	Chrome plated steel
Leak detection	Capacitive non-contact

### Technical Data

Weight/Shipping weight	13 kg / 14 kg
Maximum flow	176 l/h
Maximum working pressure	8.6 bar
Maximum suction lift	9 m water, 0.1 bar (Abs)
Maximum viscosity	12 000 centipoise
Motor installed power	0.19 kW
Remote adjustment	4-20 mA, 0-10 VDC or pulse
Inputs	2 remote inputs, 1 assignable input
Feedbacks	4-20 mA, pulse and 4 alarm contacts
Voltage (max amp)	Automatic identification: 96-264 VAC 50/60 Hz (2 amp)
Min. & max. ambient temp.	-10° to 55° C
Accuracy	± 0.5 %
Repeatability	± 0.5 %
Maximum fluid temperature	46° C
Output speed control range	1-100 % in 0.1 % increment 0.02-1 % in 0.01 % increment. 5000:1 turndown.
Enclosure	NEMA 4X / IP66
Plug type	125V AC, NEMA 5/15 (US)
	230V AC, NEMA 6/15 (US)
	230V AC, CEE7/VII (Europe)
	230V, BS 1363 (UK)
	230V AC, AS/NZS3112 (AUS)

## Dimensions in mm

	B	H	A	D	E	C
FXM2	236	307	300	329	85	155

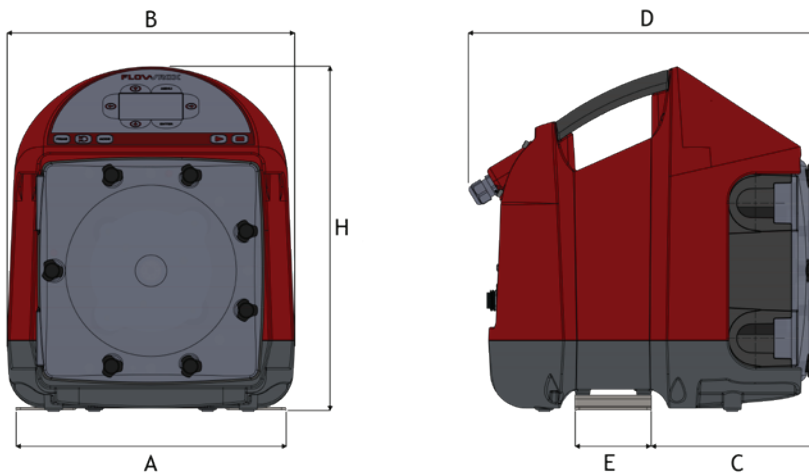

## FXM Model Matrix:

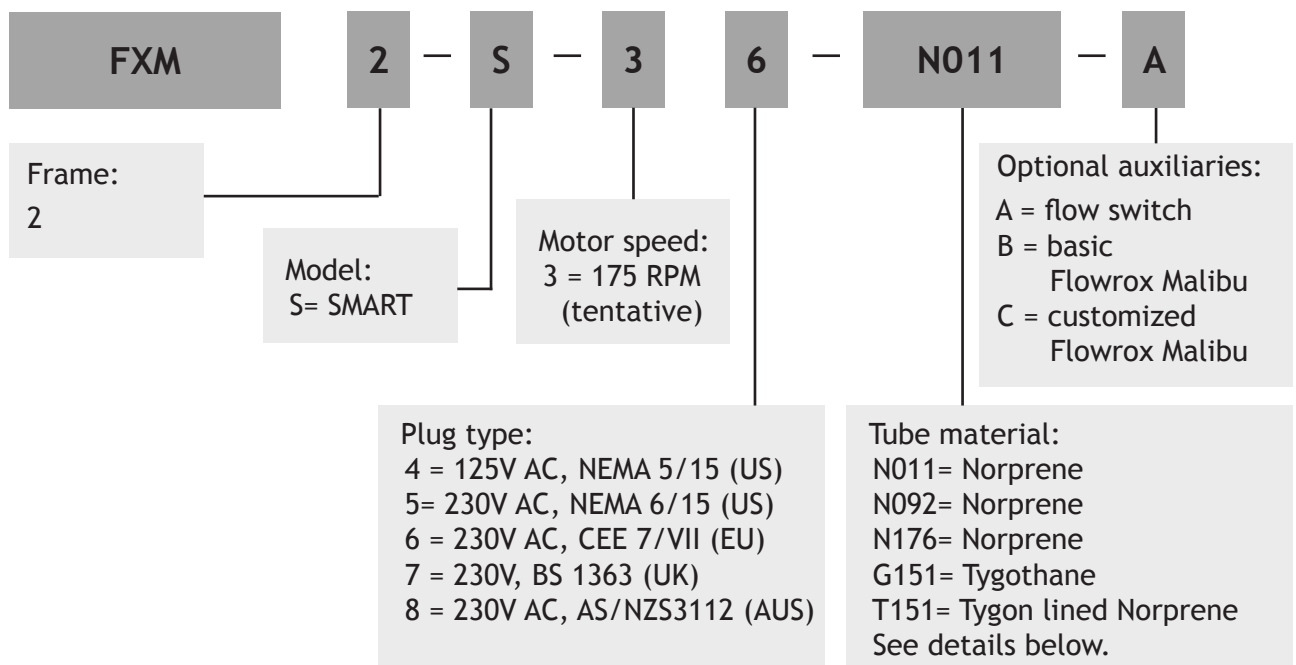

## Maximum Flow Rate and Pressure Capabilities:

Tube Number	Tubing Material	Bar	Liters per Hour
N011	Norprene	8,6	11
N092	Norprene	8,6	92
N176	Norprene	8,6	176
G151	Tygothane	4,5	151
T151	Tygon lined Norprene	3,5	151



Flowrox Oy  
P.O. Box 338, FI-53101 Lappeenranta  
Finland  
Tel. +358 201 113 311

www.flowrox.com  
info@flowrox.com

