

## Series PA/F, PA/S

# Sampling Valves

## PFA-lining or

## investment cast stainless steel



### Keep for future use!

This operating manual must be strictly observed before transport, installation, operation and maintenance

Subject to change without notice.

Reproduction is generally permitted with indication of the source.

© Richter Chemie-Technik GmbH

9510-060-en Revision 02 Edition 06/2008

## List of Contents

<b>List of Contents .....</b>	<b>2</b>	<b>7 Operation.....</b>	<b>10</b>
<b>Relevant documents.....</b>	<b>2</b>	7.1 Initial commissioning.....	10
<b>1 Technical Data .....</b>	<b>3</b>	7.2 Improper operation and their consequences .....	10
1.1 Name plate, CE and body markings.....	4	7.3 Sampling (standard) .....	10
1.2 Tightening torques.....	4	7.4 Shutdown .....	10
1.3 Flow rates.....	4	<b>8 Malfunctions .....</b>	<b>11</b>
1.4 Pressure-temperature diagram .....	4	<b>9 Maintenance.....</b>	<b>11</b>
1.5 Viscosity-pressure diagram .....	5	9.1 Dismantling PA/F .....	11
<b>2 Notes on safety.....</b>	<b>5</b>	9.2 Dismantling PA/S.....	11
2.1 Intended use.....	5	9.3 Assembly PA/F .....	12
2.2 For the customer / operator.....	6	9.4 Assembly PA/S .....	12
2.3 Improper operation .....	6	<b>10 Sectional drawings and options .....</b>	<b>12</b>
<b>3 Safety notes for applications in potentially explosive areas based on the Directive 94/9/ EC (Atex 95) .....</b>	<b>6</b>	10.1 Legend .....	12
3.1 Intended use.....	6	10.2 Sectional drawing PA/F.....	13
<b>4 Safety note for valves, certified to German Clean Air Act (TA Luft) .....</b>	<b>7</b>	10.3 Details PA/F DN 25 and DN 40.....	14
<b>5 Transport, storage and disposal .....</b>	<b>8</b>	10.4 PA/F Vertical installation .....	15
5.1 Storage .....	8	10.5 PA/F, PAP/F Option high-viscosity media. 15	
5.2 Return consignments .....	8	10.6 Sectional drawing PA/S .....	16
5.3 Disposal.....	8	10.7 Detail PA/S DN 25 .....	17
<b>6 Installation.....</b>	<b>9</b>	10.8 PA/S, PAP/S Option high-viscosity media 17	
6.1 Flange caps and gaskets .....	9	10.9 PA/S Vertical installation.....	18
6.2 Direction of flow and installation position....	9	10.10 PAP/F, PAP/S .....	18
6.3 Grounding.....	9	10.11 Dimensional rawing.....	19
6.4 Test pressure .....	9		
6.5 Star knob .....	9		
6.6 High-viscosity media / Low operating pressure .....	9		
6.7 Setting instructions .....	9		

## Relevant documents

- ◆ Declaration of conformity acc. to the EC Pressure Equipment Directive 97/23/EC
- ◆ Form for Safety Information Concerning the Contamination QM 0912-16-2001\_en
- ◆
- ◆ For PAP/F, PAP/S: Operating manual for actuator

# 1 Technical Data

## Manufacturer:

Richter Chemie-Technik GmbH  
 Otto-Schott-Str. 2  
 D-47906 Kempen  
 Telephone: +49 (0) 2152 146-0  
 Fax: +49 (0) 2152 146-190  
 E-Mail: [richter-info@richter-ct.com](mailto:richter-info@richter-ct.com)  
 Internet: <http://www.richter-ct.com>

## Designation :

### Series

- PA/F** → plastic lined, lever can be removed  
**PA/S** → Stainless steel version, without lining, lever can be removed  
**PAP/F** → Option, prepared for pneumatic, hydraulic.  
**PAP/S** or electric actuator to ISO 5211

Certified to Clean Air Act (TA-Luft)

Strength and tightness (P10, P11) of the pressure-bearing body tested to DIN EN 12266-1.

Gas-tight (P12) in the seat to DIN EN 12266-1, leak rate A

### Face to face:

DIN EN 558-1 basic series 1, ISO 5752 series 1

### Flange connecting dimensions:

DIN EN 1092-2, type B (ISO 7005-2, type B) PN 16 or flanges drilled to ASME 16.5, Class 150

## Materials :

**Body material:** Ductile cast iron EN-JS 1049 to DIN EN 1563 (0.7043 DIN 1693) or investment cast stainless steel

**Lining material:** PFA/PTFE .../F  
 On request: antistatic .../F-L  
 highly permeation-resistant .../F-P

## Temperature range : - 60 °C to + 200 °C

See pressure-temperature diagram in [Section 1.4](#).

**Operating pressure:** from vacuum to max. 16 bar

See pressure-temperature diagram in [Section 1.4](#).

## Nom. sizes :

PA/F, PAP/F DN 25, 40, 50  
 PA/S, PAP/S DN 25, 50

## Weights: ca. kg

Nom. size	25	40	50
PA/F (manually actuated)	10	18	18
PA/S (manually actuated)	9	---	14

## Installation position :

The installation position is normally horizontal with the bottle connection vertically downwards (deviations from this position require a special bottle connection). See [Section 6.2, 10.4 und 10.9](#).

## Dimensions and individual parts:

See sectional drawings in [Section 10](#).

## Options :

- ◆ Design for highly viscous media or applications with a low a low operating pressure.  
 The special flat plug produces a full cross section of the outlet opening of 10 mm at a travel of 3 mm.  
 PA/F see [Section 10.5](#)  
 PA/S see [Section 10.8](#)
- ◆ Adapter for vertical valve installation  
 PA/F see [Section 10.4](#)  
 PA/S see [Section 10.9](#)
- ◆ Sampling valve with lever locking  
 9510-00-0005
- ◆ Adapter for bottle holder, discharge spout  
 PA/F 9510-00-0012
- ◆ Sampling valve with protective cabinet  
 PA/F 9510-00-0011  
 PA/S 9510-00-0014
- ◆ Sampling valve with protective cabinet and handwheel  
 PA/S 9510-00-0015
- ◆ Sampling valve with handwheel  
 PA/F 9510-00-0017  
 PA/S 9510-00-0016
- ◆ Sampling valve with actuator  
 See [Section 10.10](#)
- ◆ Adapter for sampling bottles
- ◆ Adapter prepared for final preparation by the customer
- ◆ Adapter for small bottles with centering
- ◆ Sampling valve with septum bottle  
 PA/F 9510-00-0018
- ◆ Sampling valve with heating jacket  
 PA/S 9510-00-0019

### 1.1 Name plate, CE and body markings

The stainless steel name plate is undetachably riveted to the body.

If the operator attaches his identification, it must be ensured that the valve matches the application in question.

**Example of name plate with CE marking:**

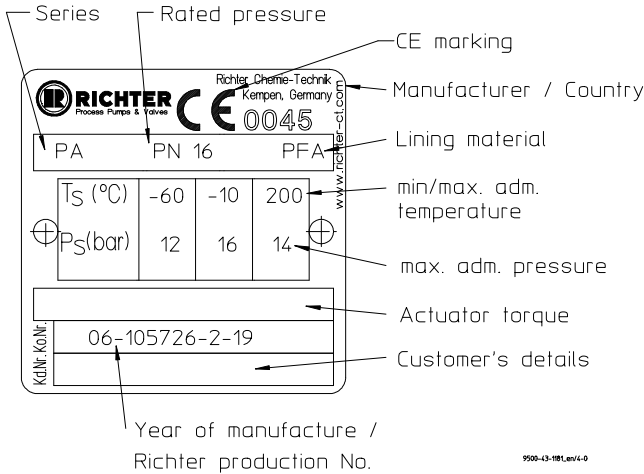

No CE marking is permissible for the size 25; the name plate therefore has no CE marking.

**Body identification :**

The following are visible on the body according to DIN EN 19 and AD 2000 A4:

- ◆ Nominal size
- ◆ Rated pressure
- ◆ Body material
- ◆ Manufacturer's identification
- ◆ Melt number/Foundry identification
- ◆ Foundry date

### 1.2 Tightening torques

**All screws greased, tighten in diametrically opposite sequence!**

The tightening torques for pipe screws and body screws mentioned must not be exceeded. For an exception, see **Section 8**, Flange connection valve / pipe is leaking.

The following tightening torques are recommended:

**Pipe screws**

Flange nom. size [mm]	Screws [ISO/DIN]	Tightening torque [Nm]
25	4 x M12	10
40	4 x M16	20
50	4 x M16	26

**Pipe screws**, flanges ISO/DIN drilled to ASME Class 150

Flange nom. size [mm]	[inch]	Screws [ASME]	Tightening torque	
			[in-lbs]	[Nm]
25	1"	4 x 1/2"	70	8
40	1 1/2"	4 x 1/2"	135	15
50	2"	4 x 5/8"	220	25

**Body screws**

Nom. size [mm]	Screws [ISO/DIN]	Tightening torque [Nm]
25	4 x M12	30
40	4 x M16	50
50	4 x M16	50

### 1.3 Flow rates

Nom. size [mm]	[inch]	Ventildurchfluss kv100 [Cv]	Probenahme bei max. Ventilhub	
		[m³/h]	[USgpm]	
25	1"	15 [17.5]	0,385 [0.448]	2,56 [2.98]
40	1 1/2"	47 [54.8]		
50	2"	65 [75.7]		

### 1.4 Pressure-temperature diagram

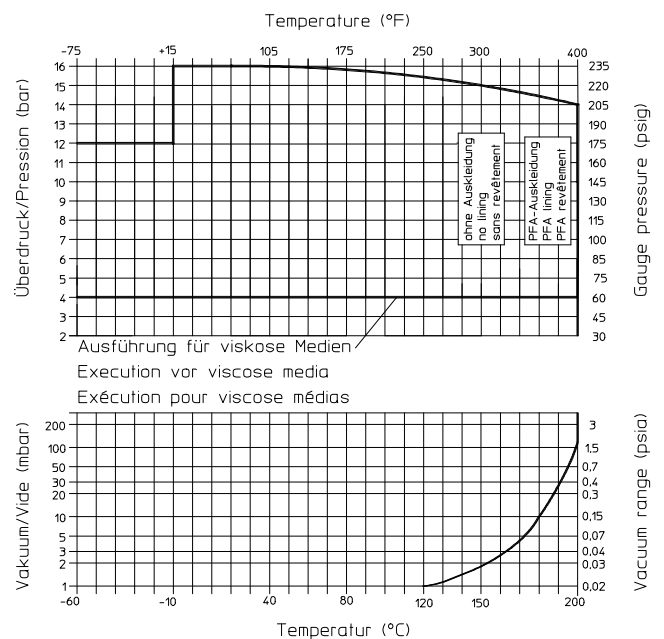

### 1.5 Viscosity-pressure diagram

The appropriate valve plug is selected in accordance with this diagram. In the case of different operating parameters, please consult Richter.

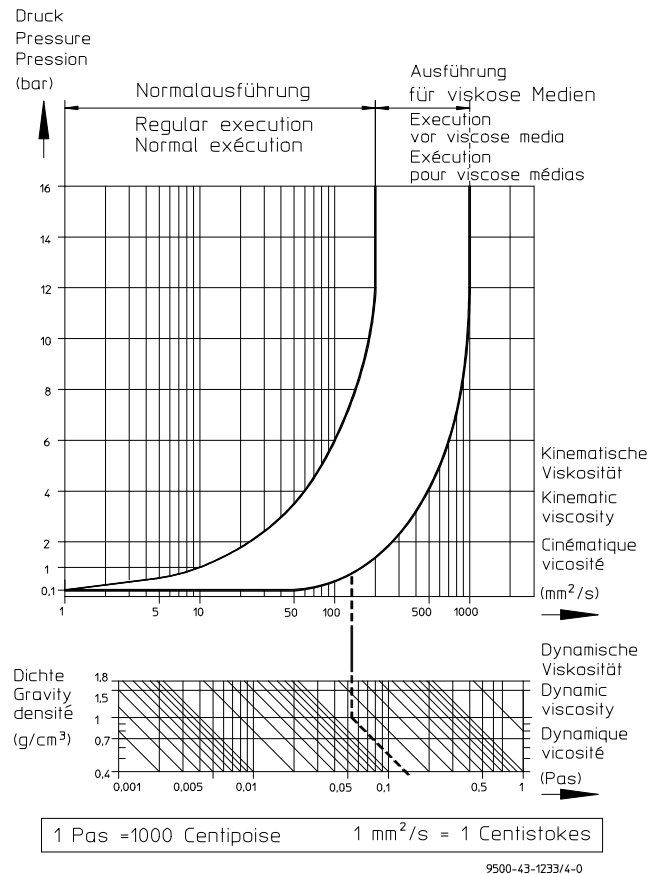

## 2 Notes on safety

This operating manual contains fundamental information which is to be observed during installation, operation and maintenance.

**It must therefore be read before installation and commissioning!**

For valves which are used in potentially explosive areas, see **Section 3**.

Installation, operation and maintenance are to be performed by qualified staff.

The area of responsibility, authority and supervision of the staff must be regulated by the customer.



**General hazard symbol!**  
People may be put at risk.



**Safety symbol!** The valve and its function may be put at risk if this safety symbol is not observed.

It is imperative to observe warnings and signs attached directly to the valve and they are to be kept fully legible.

**Non-observance of the notes on safety may result in the loss of any and all claims for damages.**

For example, non-observance may involve the following hazards:

- ◆ Failure of important functions of the valve/plant.

- ◆ Risk to people from electric, mechanical and chemical effects.
- ◆ Risk to the environment through leaks of hazardous substances.

### 2.1 Intended use

Richter sampling valves are pressure-maintaining components in accordance with the Pressure Equipment Directive (DGRL) for taking liquid samples. The standard PA/F and PA/S are only intended for horizontal installation (vertical installation only with special adapter).

The valves are suitable for non-boiling liquids of group 1 in accordance with the Pressure Equipment Directive.

**Solids** can lead to increased wear, damage to sealing surfaces or to a reduction in the service life of the valve.

The operator must carefully examine in the event of operating data other than those provided whether the designs of the valve, accessories and materials are suitable for the new application (consult the manufacturer).

## 2.2 For the customer / operator

If a valve is used, the operator must ensure that

- ◆ actuators which are retrofitted are adapted to suit the valve
- ◆ hot or cold valve parts are protected by the customer against being touched
- ◆ the valve has been properly installed in the pipe system
- ◆ the usual flow rates are not exceeded in continuous operation.

This is not the manufacturer's responsibility.

Loads caused by earthquakes were not allowed for in the design.

Fire protection to DIN EN ISO 10497 is not possible (plastic lining and plastic components).

## 2.3 Improper operation

The operational reliability of the valve supplied is only guaranteed if it is used properly in accordance with **Section 2.1** of this operating manual.



The operation limits specified on the identification plate and in the pressure-temperature diagram must under no circumstances be exceeded.

# 3 Safety notes for applications in potentially explosive areas based on the Directive 94/9/ EC (Atex 95)

The valves are intended for use in a potentially explosive area and are therefore subject to the conformity assessment procedure of the directive 94/9/EC (ATEX).

As part of this conformity assessment, an ignition hazard analysis to EN 13463-1 to satisfy the fundamental safety and health requirements was conducted with the following result:

- ◆ **The valves do not have any ignition source of their own and can be operated both manually as well as mechanically/electrically.**
- ◆ **The valves are not covered by the scope of application of the ATEX directive and therefore do not need to be identified accordingly.**
- ◆ **The valves may be used in a potentially explosive area.**

Supplementary notes:

- ◆ **Electric/mechanical actuators must be subjected to their own conformity assessment to ATEX.**

It is imperative to observe the individual points of intended use for application in a potentially explosive area.

## 3.1 Intended use

Improper operation, even for brief periods, may result in serious damage to the unit.

In connection with explosion protection, potential sources of ignition (overheating, electrostatic and induced charges, mechanical and electric sparks) may result from these improper operation; their occurrence can only be prevented by adhering to the intended use.

Furthermore, reference is made in this connection to the Directive 95/C332/06 (ATEX 118a) which contains the minimum regulations for improving the occupational health and safety of the workers who may be at risk from an explosive atmosphere.

A difference is made between two cases for the use of chargeable liquids (conductivity  $<10^{-8}$  S/m):

### 1. Chargeable liquid and non-conductive lining

Charges can occur on the lining surface. As a result, this can produce discharges inside the valve. However, these discharges cannot cause ignitions if the valve is completely filled with medium.

If the valve is not completely filled with medium, e.g. during evacuation and filling, the formation of an explosive atmosphere must be prevented, e.g. by superimposing a layer of nitrogen.

It is recommended to wait 1 hour before removing the valve from the plant in order to permit the elimination of static peak charges.

This means that, to safely prevent ignitions, the valve must be completely filled with medium at all times or else a potentially explosive atmosphere must be excluded by superimposing a layer of inert gas.

## 2. Chargeable liquid and conductive lining

No hazardous charges can occur as charges are discharged direct via the lining and shell (surface resistance  $<10^9$  Ohm, leakage resistance  $<10^6$  Ohm).

**Static discharges of non-conductive linings are only produced through the interaction with a non-conductive medium and are therefore the responsibility of the plant operator.**

**Static discharges are not sources of ignition which stem from the valves themselves!**

- The temperature of the medium must not exceed the temperature of the corresponding temperature class or the maximum admissible medium temperature as per the operating manual.
- If the valve is heated (e.g. heating jacket), it must be ensured that the temperature classes prescribed in the Annex are observed.
- To achieve safe and reliable operation, it must be ensured in inspections at regular intervals that the valve is properly serviced and kept in technically perfect order.

- Increased wear to the valve can be expected with the conveyance of liquids containing abrasive constituents. The inspection intervals are to be reduced compared with the usual times.
- Actuators and electric peripherals, such as temperature, pressure and flow sensors etc., must comply with the valid safety requirements and explosion protection provisions.
- The valve must be grounded. This can be achieved in the simplest way via the pipe screws using tooth lock washers. Otherwise grounding must be ensured by other action, e.g. cable bridges.
- Attachments such as actuators, position controllers, limit switches etc. must satisfy the relevant safety regulations as regards explosion protection and, if required, be designed in compliance with ATEX.
- Special attention must be paid to the appropriate safety and explosion protection notes in the respective operating manuals.
- Plastic-lined valves must not be operated with carbon disulphide.

## 4 Safety note for valves, certified to German Clean Air Act (TA Luft)

On request, this valve can be supplied compliant with the German Clean Air Code.

Certificate / Manufacturer Declaration Validity is dependent on the operating instructions being read and observed.

In particular, servicing must be conducted at regular intervals, and the bolted connections relevant for tightness must be inspected and retightened if necessary.

## 5 Transport, storage and disposal



It is imperative, for all transport work, to observe generally accepted engineering practice and the accident prevention regulations.



The valve is supplied with flange caps. Do not remove them until just before installation. They protect the plastic surfaces against dirt and mechanical damage.

Handle the goods being transported with care. During transport the valve must be protected against impacts and collisions.

Directly after receipt of the goods, the consignment must be checked for completeness and any in-transit damage.

Transport securing device:

Set the star knob so that the travel is limited to the minimum flow. The lever has a safety function and must swing freely (dead man's position).

Transporting the valve using the lever is not permitted.

Do not damage the external epoxy coating.

### 5.1 Storage

If the valve is not installed immediately after delivery, it must be put into proper storage.

It should be stored in a dry, vibration-free and well-ventilated room at as constant a temperature as possible.

Elastomers are to be protected against UV light.

In general, a storage period of 10 years should not be exceeded.

### 5.2 Return consignments



Valves which have conveyed aggressive or toxic media must be well rinsed and cleaned before being returned to the manufacturer's works.

It is **imperative** to enclose a **safety information sheet / general safety certificate** on the field of application with the return consignment.

Pre-printed forms are enclosed with the installation and operating manual.

Safety precautions and decontamination measures are to be mentioned.

### 5.3 Disposal

Parts of the valve may be contaminated with medium which is detrimental to health and the environment and therefore cleaning is not sufficient.



Risk of personal injury or damage to the environment due to the medium!

- ◆ Wear protective clothing when work is performed on the valve.
- ◆ Prior to the disposal of the valve:
  - Collect any medium, etc. which has escaped and dispose of it in accordance with the local regulations.
  - Neutralise any medium residues in the valve.
- ◆ Separate valve materials (plastics, metals, etc.) and dispose of them in accordance with the local regulations

## 6 Installation

- ◆ Examine valve for in-transit damage, damaged ball valves must not be installed.
- ◆ Before installation the valve and the connecting pipe must be carefully cleaned to remove any dirt, especially hard foreign matter.
- ◆ During installation, pay attention to the correct tightening torque, aligned pipes and tension-free assembly.
- ◆ It must be ensured that the lever swings freely (dead man's position).



Ensure that a remotely actuated actuator cannot be accidentally switched on.

### 6.1 Flange caps and gaskets

- ◆ Leave protective caps on the flanges until just prior to installation.

Where there is a particularly high risk of damage to the plastic sealing surfaces, e.g. if the mating flanges are made of metal are glass-lined, PTFE-lined gaskets with a metal inlay should be used. These gaskets are available as special accessories in the Richter range.

### 6.2 Direction of flow and installation position

Installation is independent of the direction of flow.

The installation position is normally horizontal with the bottle connection pointing vertically downwards (deviations from this position require a special bottle connection). See [Section 10.4 and 10.9](#).

### 6.3 Grounding

The valve must be grounded. The simplest solution is to use tooth lock washers which are placed under one pipe bolt of each flange.

Otherwise grounding must be ensured by different measures e.g. a cable link.

At the customer's request a setscrew M6 with a hex. nut and washer will be provided at each flange as an additional grounding connection.

### 6.4 Test pressure

The test pressure PT of an open valve must not exceed the value of  $1.5 \times PS(PN)$  as per the identification of the valve.

### 6.5 Star knob

The stroke and thus the pressure reduction and medium flow can be influenced with the star knob.

Moreover, the star knob can be used to close the valve like a manual valve.

It also served to enforce tightness in case of damaged seat sealing surfaces or seized particles.

### 6.6 High-viscosity media / Low operating pressure

With the version "design for high-viscosity media" the changed operating limits acc. to the name plate must be observed and the travel must be set according to the setting instructions in [Section 6.7](#).

### 6.7 Setting instructions

- Press the sampling lever in the direction of the valve.
- Slowly turn the star knob counterclockwise until the flow into the sampling bottle corresponds to the intensity you want.
- Release lever and lock the star knob in this position.

This procedure guarantees that with each further sampling process (with the same internal pressure) the flow of the sample into the bottle remains within the desired range without any risk to the person taking the sample.

If the operating pressures vary, we recommend you for safety's sake to turn the star knob after every sampling operation clockwise again until it reaches zero point (lever cannot execute any travel).

## 7 Operation

### 7.1 Initial commissioning



Normally, the ball valves have been tested for leaks with air or water. Prior to initial operation check body bolting. For torques see **Section 1.2**.

Unless otherwise agreed, there could be residual amounts of water in the flow section of the ball valve; this could result in a possible reaction with the medium.

To prevent leaks, all connection screws should be retightened after the initial loading of the valve with operating pressure and operating temperature.

For torques see **Section 1.2**.

### 7.2 Improper operation and their consequences

- ◆ Crystallisation may result in damage to the seat rings or ball/stem unit. This can be prevented by heating.
- ◆ In extreme cases a leak may occur.
- ◆ Increased wear occurs when the valve is operated with solid contents.
- ◆ Violent opening or rapid filling may cause the bottle to burst.
- ◆ Non-observance of the pressure-temperature diagram may result in damage.
- ◆ Do not transport the valve using the lever.
- ◆ Do not use a lever extension as otherwise there is a risk of damage.
- ◆ At the customer's request, the middle hole in the lever is drilled through. If the lever is then locked in the lower hole to take samples and if, in addition, a pin is inserted into the middle hole, it must be ensured that sampling does not take place accidentally.

### 7.3 Sampling (standard)

At the customer's request, the hole is drilled through

Dead's man position

Lever secured

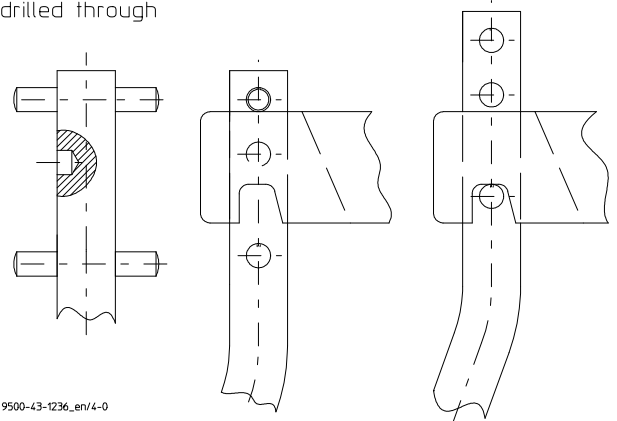

- Screw bottle into the bottle connection **226**.
- Check travel set on the star knob **963/1**.
- Lever **203** is in the dead man's position.
- For sampling, lock lever in the top groove.
- If it is requested that the lever is firmly locked, drill through the middle hole and insert an additional pin into the middle hole.  
**CAUTION!** Sampling may also take place accidentally.
- Press in direction of valve.
- Sampling can take place.

A lock is available from Richter as an option.

A device for the risk-free discharge of the medium must be connected to the venting connection.

Sealing plugs are inadmissible as overpressure occurs in the bottle.

### 7.4 Shutdown

The local regulations are to be observed when dismantling the valve.

Prior to undoing the flange connection ensure, that the plant is depressurised and emptied.



Prior to starting any repair work, the valve is to be thoroughly cleaned. Even if the valve has been properly emptied and rinsed, residual medium may still be found in the valve.

After dismantling, immediately protect the valve flanges against mechanical damage with flange caps.

See also **Section 5.1**.

## 8 Malfunctions

- ◆ Flange connection ball valve/pipe is leaking  
Retighten the flange screws to a tightening torque according to **Section 1.2**. If this does not remedy the leak, the recommended torques may be exceeded by 10%.  
If this also fails to stop the leak, dismantle and inspect the ball valve.
- ◆ Flange connection body/seat or body/cover is leaking  
Retighten body screws. See paragraph "Flange connection ball valve/pipe is leaking".
- ◆ Packing leaks  
Bellows leaking.  
Retighten safety packing and switch off plant as quickly as possible and isolate pipe section with valve.
- ◆ Valve does not close tight  
Loosen lock nut under the star knob and close the valve using the star knob.

## 9 Maintenance

- ◆ All repair work is to be performed by qualified personnel using the appropriate tools. Generally recognised practice in mechanical engineering is to be observed.
- ◆ For the arrangement, designation and item numbers of all parts of the valve, see **Section 10**.
- ◆ Spare parts are to be ordered with all the details in acc. with the valve identification.
- ◆ Only original spare parts may be installed.
- ◆ To prevent leaks, a regular check of the connection screws should be made in line with the operating requirements.  
For torques see **Section 1.2**.



Make sure that when working on the sampling valve it is drained.

See also **Section 7.4**

### 9.1 Dismantling PA/F

- Undo clip **937/1** and unscrew bottle connection **226**.
- Undo groove nut **509/1**. Star knob **963/1** can remain screwed in.
- Unscrew spring bonnet **513**.
- Pull pressure spring **952/1** off the stem **855**.
- Undo setscrew **904/1** in spring bush **514**.
- Unscrew spring bush **514**.
- Unscrew hex. nut **920/4** with tooth lock washer **936/2**, remove seat **205**.
- Unscrew hex. nut **920/2** with tooth lock washer **936/1**, remove cover **106**.
- Pull out bellows **206** with stem **855** downwards.
- Remove actuation **515** from cover.

If the packing rings have to be replaced:

- Unscrew hex. nut **920/1**.

- Remove packing gland follower **503**.
- Pull thrust ring **405** out of cover.
- Replace packing rings **402/1**.  
**CAUTION:** Offset overlapping from ring to ring by 60°- 90°.
- Insert thrust ring **405** into cover.
- Mount packing gland follower **503** onto stud screws **902/1** and pre-assemble with hex. nut **920/1**.

### 9.2 Dismantling PA/S

- Unscrew cap nut **927/1**, remove disc **550** and bottle connection **226**.
- Undo groove nut **509/1**. Star knob **963/1** can remain screwed in.
- Unscrew spring bonnet **513**.
- Pull pressure spring **952/1** off the stem **855**.
- Undo setscrew **904/1** in spring bush **514**.
- Unscrew spring bush **514**.
- Unscrew hex. nut **920/2**, remove cover **106**, remove threaded rod **918/1**.
- Pull out bellows **206** with stem **855** downwards.
- Remove actuation **515** from the cover.

If the packing rings have to be replaced:

- Unscrew hex. nut **920/1**.
- Remove packing gland follower **503**.
- Pull thrust ring **405** out of cover.
- Replace packing rings **402/1**.  
**CAUTION:** Offset overlapping from ring to ring by 60°- 90°.
- Insert thrust ring **405** into cover.
- Mount packing gland follower **503** onto stud screws **902/1** and pre-assemble with hex. nut **920/1**.

### 9.3 Assembly PA/F

- Mount seat **205** and screw tight with hex. nut **920/4** and tooth lock washer **936/2**.
- Introduce stem **855** and bellows **206** into cover **106**.
- When doing so, also install actuation **515**. Move lever into dead man's position. See [Section 7.3](#).
- Screw cover **106** tight to body **100** with hex. nut **920/2** and tooth lock washer **936/1**.
- Screw on spring bush **514**. Insert spring bush until actuation **515** contacts slightly with the lower edge of the upper cover flange. Tighten with setscrew **904/1**.
- Insert pressure spring **952/1**.
- Screw in spring bonnet **513**, lock with groove nut **509/1**. The spring bonnet is to be flush with the lower edge of the upper cover flange.
- Slightly tighten hex. nut **920/1** of the packing.
- Standard: Screw in bottle connection **226** and secure with clip.
- Set travel on star knob. See [Section 6.7](#).

### 9.4 Assembly PA/S

- Screw stem **855** into bellows **206**.
- Insert stem **855** and bellows **206** into cover **106**.
- When doing so, also mount actuation **515**. Move lever into dead man's position. See [Section 7.3](#).
- Screw cover **106** tight onto body **100** with threaded rod **918/1** and hex. nut **920/2**.
- Screw on spring bush **514**. Insert spring bush until actuation **515** contacts slightly with the lower edge of the upper cover flange. Tighten with setscrew **904/1**.
- Insert pressure spring **952/1**.
- Mount spring bonnet **513** with groove nut **509/1**. The spring bonnet is to be flush with the lower edge of the upper cover flange.
- Slightly tighten hex. nut **920/1** of the packing.
- Standard: Secure bottle connection **226** with threaded rod **918/1** and cap nut **927/1**.
- Set travel on star knob. See [Section 6.7](#).

## 10 Sectional drawings and options

### 10.1 Legend

<b>100</b>	body	<b>515</b>	actuation
<b>104</b>	transition flange (DN 40)	<b>554/1</b>	washer (DN 25, DN 40)
<b>106</b>	cover	<b>561/1</b>	grooved pin
<b>203</b>	lever	<b>804</b>	coupling
<b>205</b>	seat	<b>850</b>	actuator
<b>206</b>	bellows	<b>855</b>	stem
<b>226</b>	bottle connection	<b>902/x</b>	stud screw
<b>302/1</b>	guide ring	<b>902/4</b>	stud screw (DN 40)
<b>302/2</b>	guide ring (DN 40)	<b>904/x</b>	setscrew
<b>400/1</b>	O-ring	<b>917/1</b>	screw-in pipe connector
<b>402/1</b>	packing ring	<b>920/x</b>	hex. nut
<b>405/1</b>	thrust ring	<b>920/5</b>	hex. nut (DN 40)
<b>407</b>	seal ring (DN 40)	<b>936/x</b>	toothed lock washer
<b>500</b>	ring	<b>936/3</b>	toothed lock washer (DN 40)
<b>503</b>	packing gland follower	<b>937/1</b>	clip
<b>509/x</b>	groove nut	<b>952/1</b>	pressure spring
<b>510</b>	bracket	<b>963/1</b>	star knob
<b>513</b>	spring bonnet	<b>964/1</b>	ball head
<b>514</b>	spring bush		

10.2 Sectional drawing PA/F

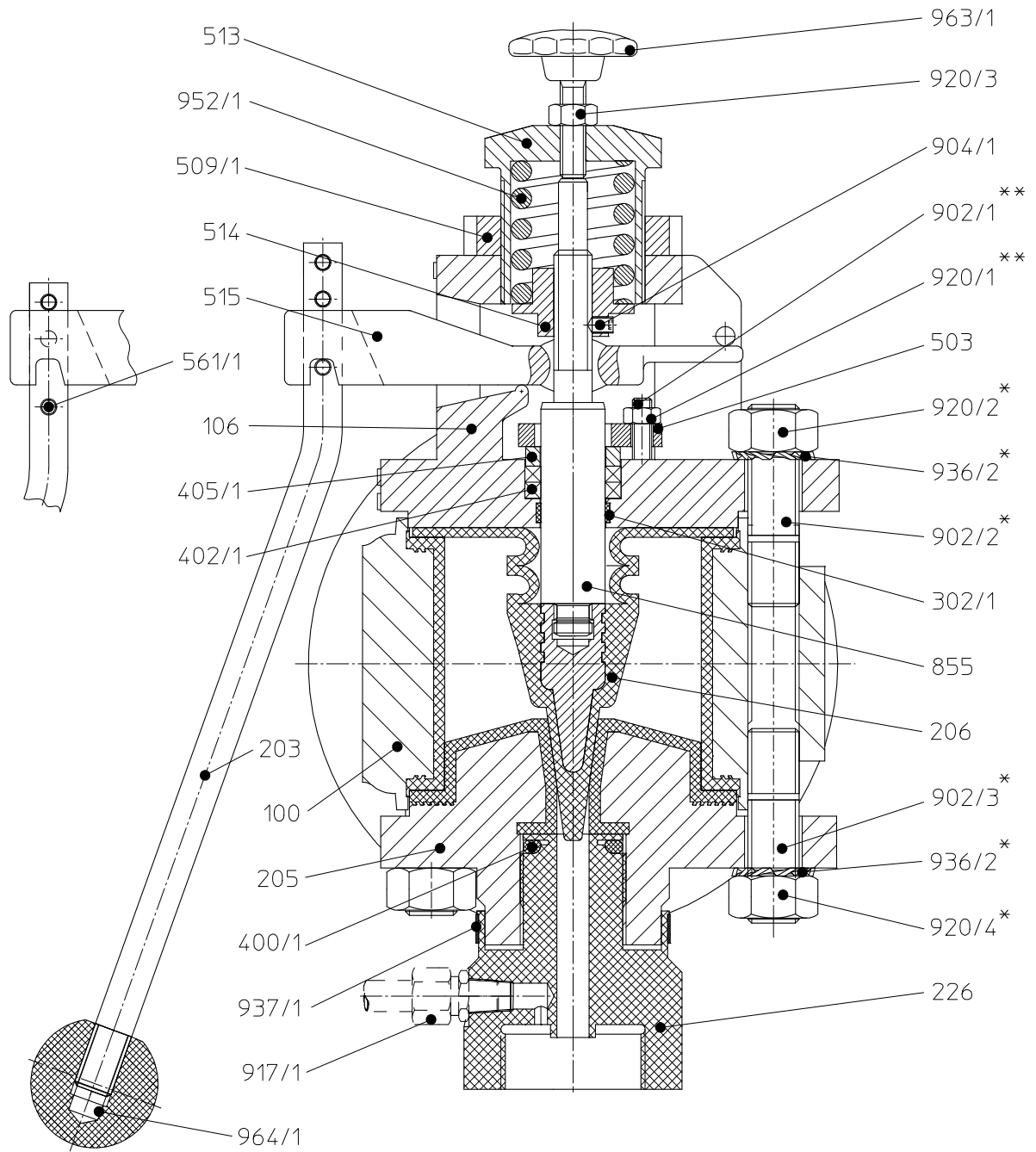

\* um 90° versetzt gezeichnet  
view displaced by 90°

\*\* um 45° versetzt gezeichnet  
view displaced by 45°

10.3 Details PA/F DN 25 and DN 40

PA/F DN 25

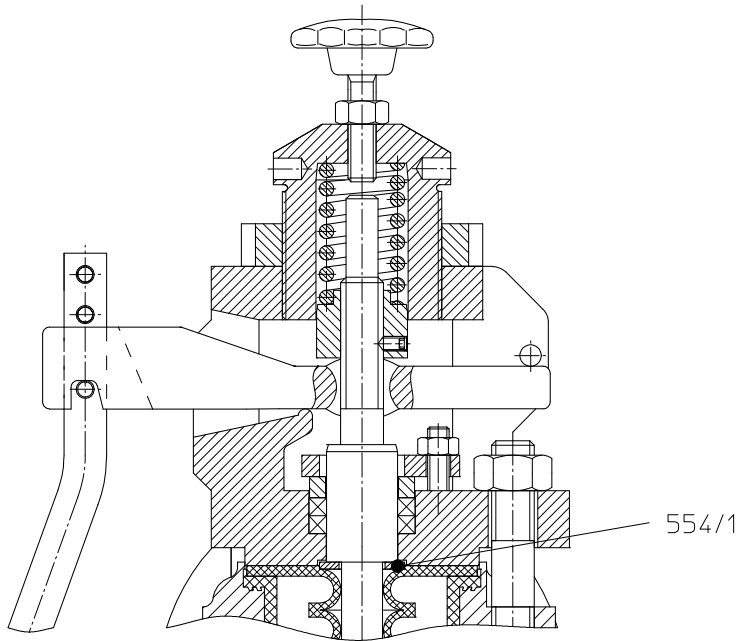

PA/F DN 40

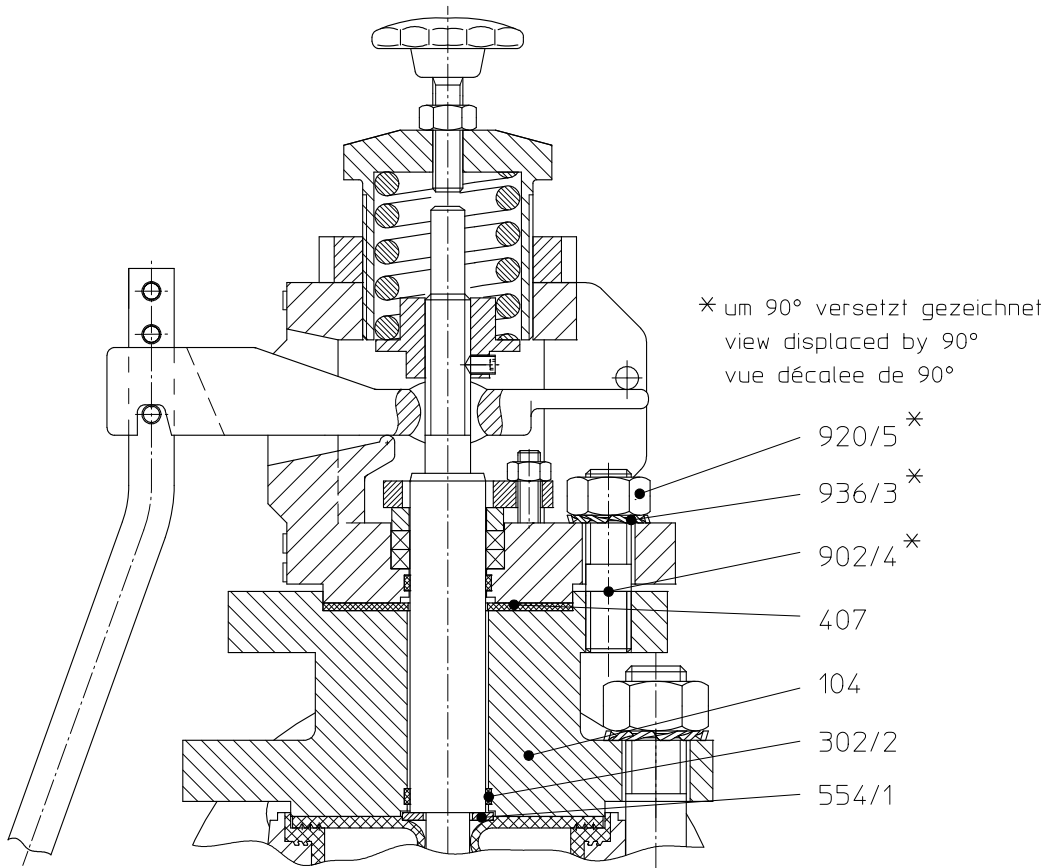

**10.4 PA/F Vertical installation**

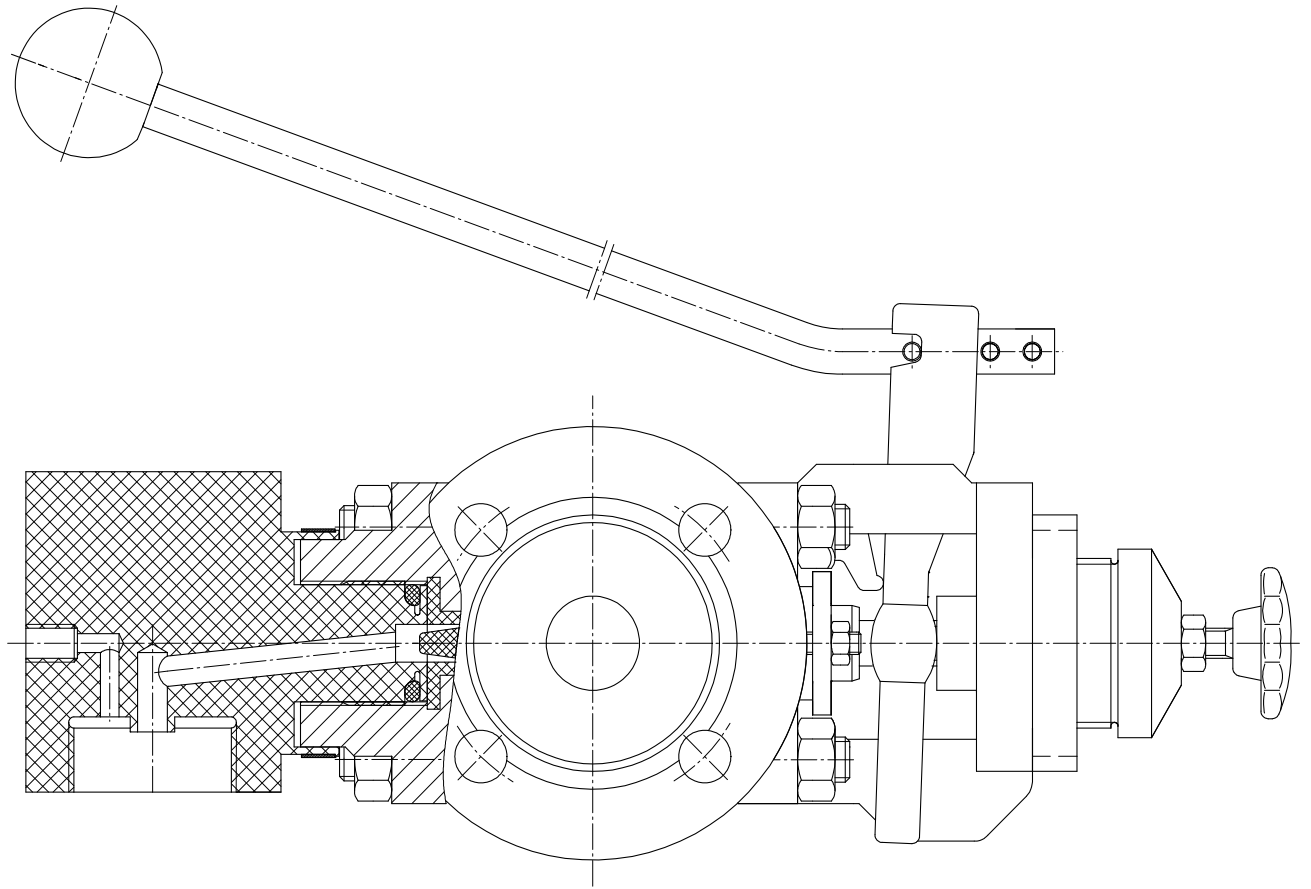

**10.5 PA/F, PAP/F Option high-viscosity media**

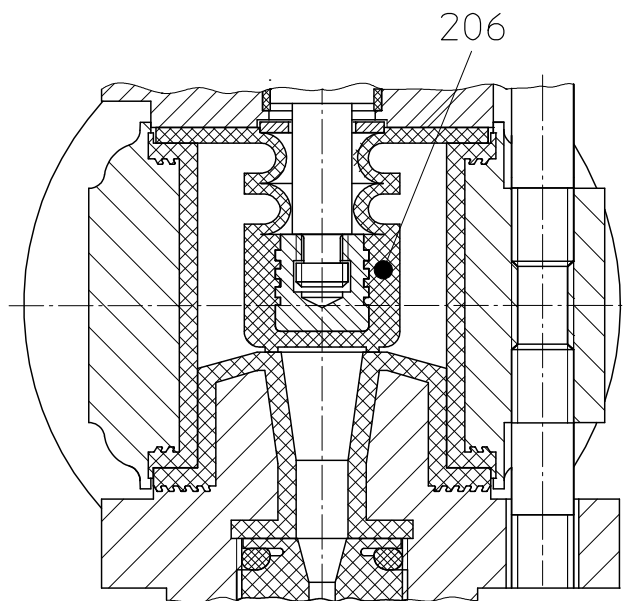

10.6 Sectional drawing PA/S

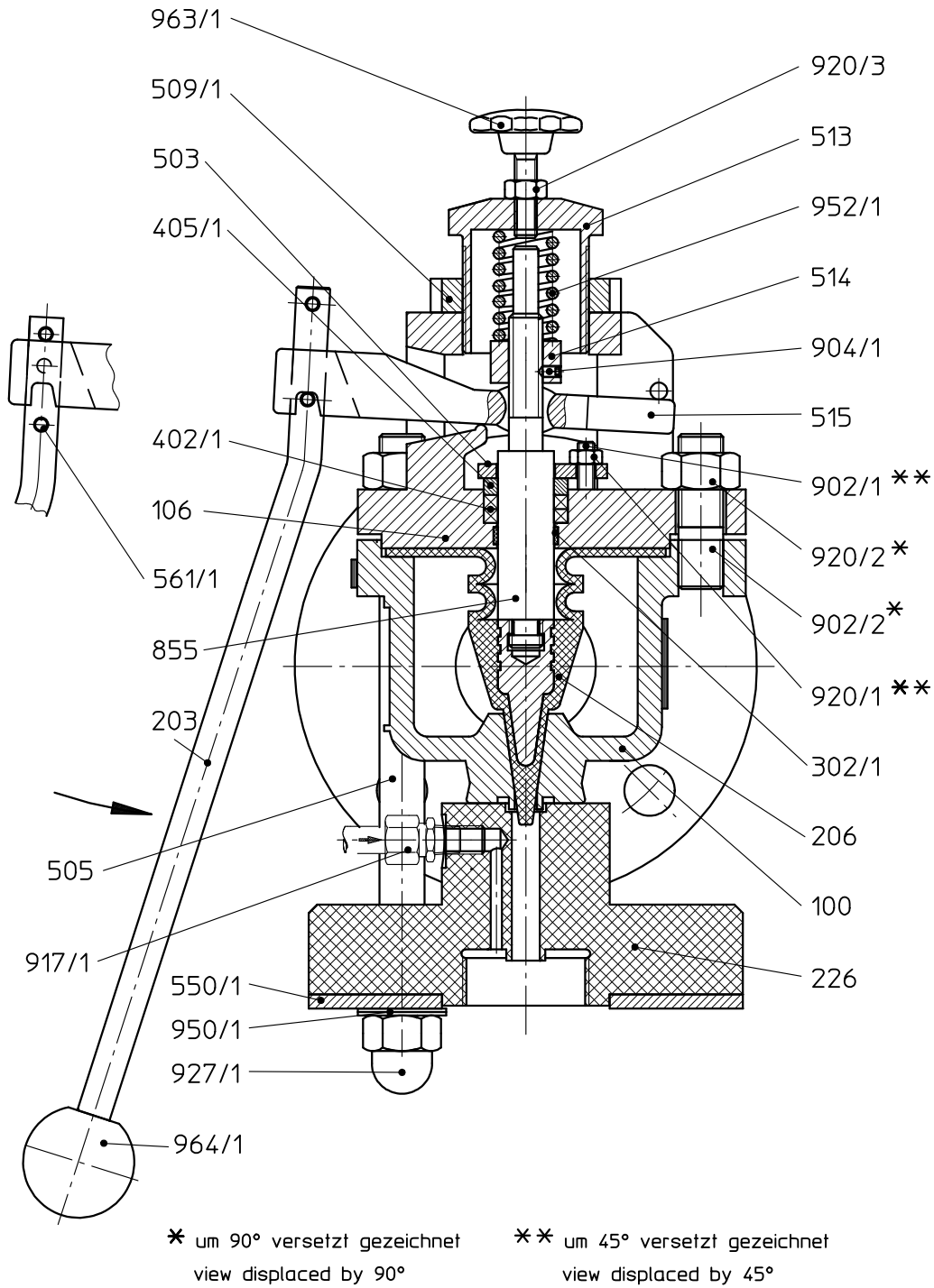

10.7 Detail PA/S DN 25

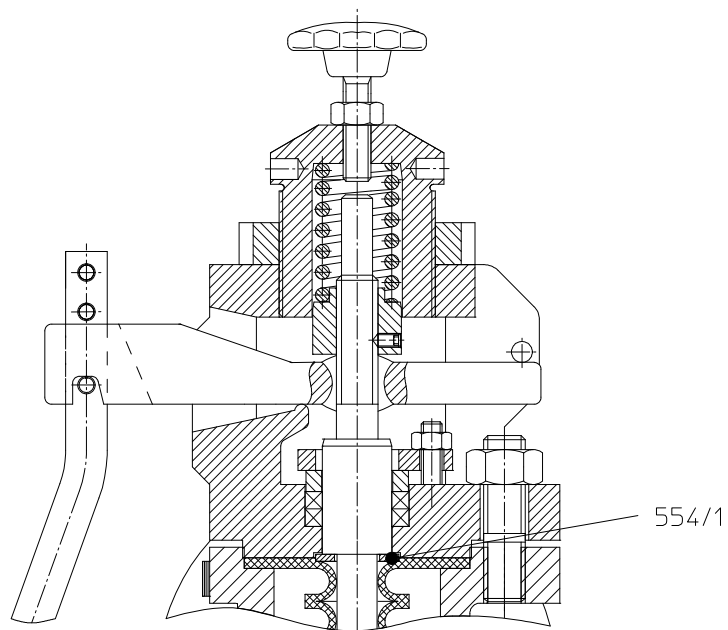

10.8 PA/S, PAP/S Option high-viscosity media

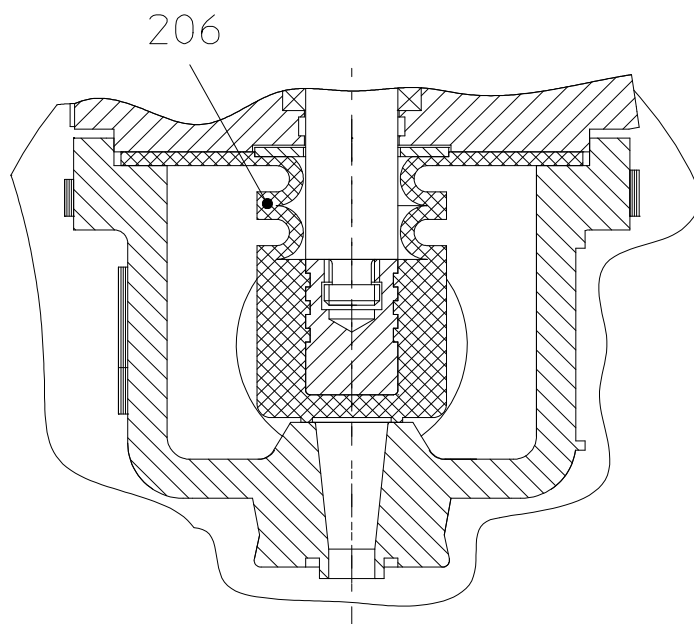

10.9 PA/S Vertical installation

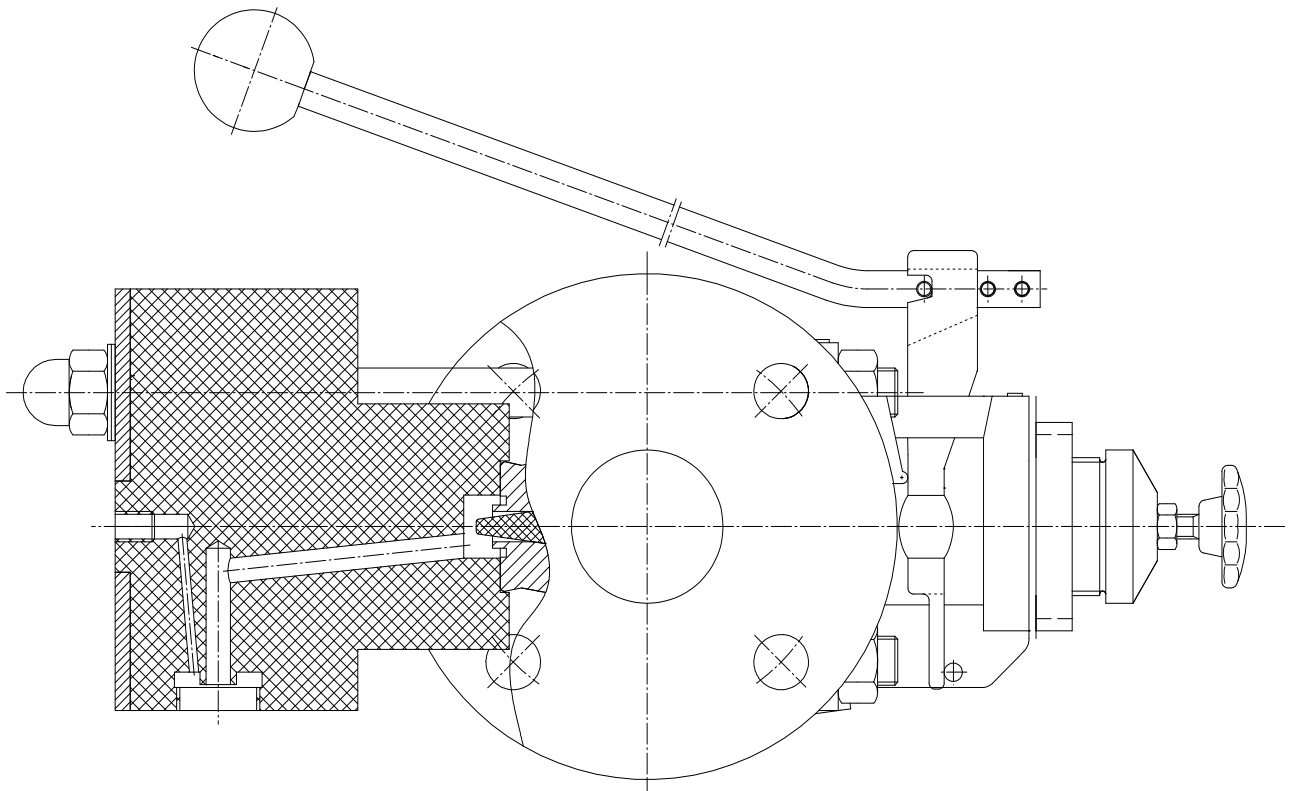

10.10 PAP/F, PAP/S

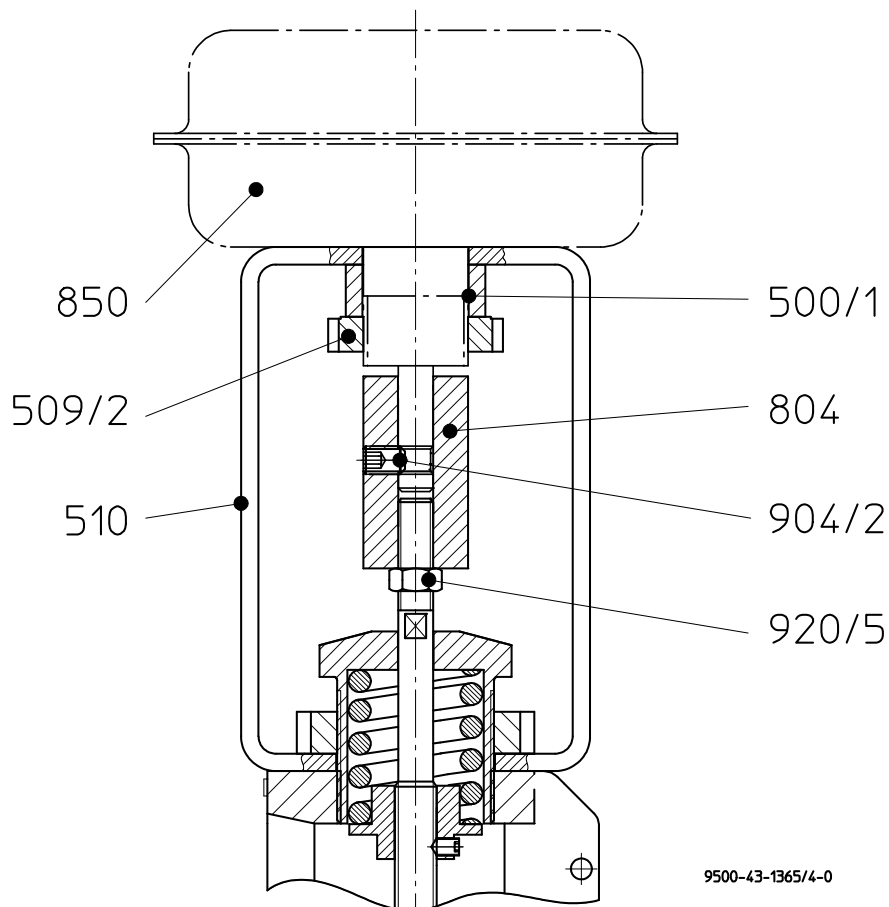

9500-43-1365/4-0

10.11 Dimensional drawing

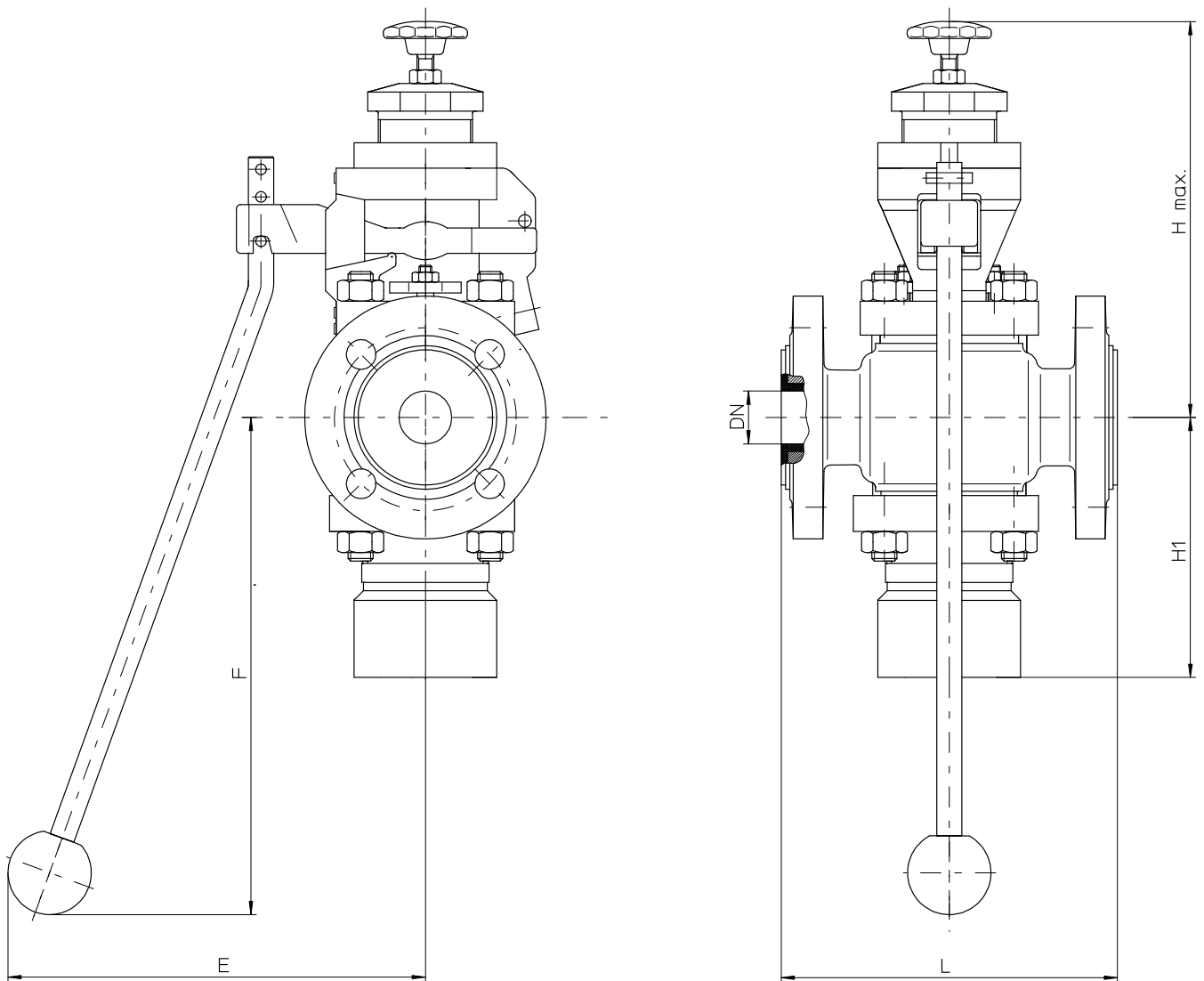

DN		H1		H max.		E		F		L EN 558 Reihe 1	
mm	inch	mm	inch	mm	inch	mm	inch	mm	inch	mm	inch
25	1"	123	4.84	190	7.48	ca.200	ca.7.87	ca.235	ca.9.25	160	6.3
40	1½"	127	5.0	250	9.84	ca.200	ca.7.87	ca.175	ca.6.89	200	7.87
50	2"	131	5.16	195	7.68	ca.200	ca.7.87	ca.230	ca.9.06	230	9.06

Flanschanschlussmaße:

DIN EN 1092-2, Form B (ISO 7005-2, Form B) PN 16 oder Flansche gebohrt nach ASME B16.5 Class 150

## Safety Information / **Declaration of No Objection** Concerning the Contamination of Richter-Pumps, -Valves and Components

### 1 SCOPE AND PURPOSE

Each entrepreneur (operator) carries the responsibility for the health and safety of his employees. This extends also to the personnel, who implements repairs with the operator or with the contractor.

Enclosed declaration is for the information of the contractor concerning the possible contamination of the pumps, valves and component sent in for repair. On the basis of this information for the contractor is it possible to meet the necessary preventive action during the execution of the repair.

Note: The same regulations apply to repairs **on-site**.

### 2 PREPARATION OF DISPATCH

Before the dispatch of the aggregates the operator must fill in the following declaration completely and attach it to the shipping documents. The shipping instructions indicated in the respective manual are to be considered, for example:

- Discharge of operational liquids
- remove filter inserts
- lock all openings hermetically
- proper packing
- Dispatch in suitable transport container
- Declaration of the contamination fixed **outside!!** on the packing

# Declaration about the Contamination of Richter Pumps, -Valves and Components

The repair and/or maintenance of pumps, valves and components can only be implemented if a completely filled out declaration is available. If this is not the case, delay of the work will occur. If this declaration is not attached to the devices, which have to be repaired, the transmission can be rejected.

**Every aggregate has to have it's own declaration.**

This declaration may be filled out and signed only by authorized technical personnel of the operator.

Contractor/dep./institute : _____ Street : _____ Postcode, city: _____ Contact person: _____ Phone : _____ Fax : _____ End user : _____	Reason for transmitting <input checked="" type="checkbox"/> Please mark the applicable <b>Repair:</b> <input type="checkbox"/> subject to fee <input type="checkbox"/> Warranty <b>Exchange:</b> <input type="checkbox"/> subject to fee <input type="checkbox"/> Warranty <input type="checkbox"/> Exchange/ Replacement already initiated/received <b>Return:</b> <input type="checkbox"/> Leasing <input type="checkbox"/> Loan <input type="checkbox"/> for credit note																																												
<b>A. Details of Richter-product:</b>																																													
<b>Classification:</b> _____ <b>Article number:</b> _____ <b>Serial number:</b> _____	<b>Failure description:</b> _____ <b>Equipment:</b> _____ <b>Application tool:</b> _____ <b>Application process:</b> _____																																												
<b>B. Condition of the Richter-product:</b>																																													
<table border="1" style="width:100%; border-collapse: collapse;"> <thead> <tr> <th style="width:30%;"></th> <th style="width:10%; text-align: center;">no<sup>1)</sup></th> <th style="width:10%; text-align: center;">yes</th> <th style="width:10%; text-align: center;">no</th> </tr> </thead> <tbody> <tr> <td>Was it in operation ?</td> <td style="text-align: center;"><input type="checkbox"/></td> <td style="text-align: center;"><input type="checkbox"/></td> <td style="text-align: center;"><input checked="" type="checkbox"/></td> </tr> <tr> <td>Drained (product/operating supply item) ?</td> <td style="text-align: center;"><input checked="" type="checkbox"/></td> <td style="text-align: center;"><input type="checkbox"/></td> <td style="text-align: center;"><input type="checkbox"/></td> </tr> <tr> <td>All openings hermetically locked!</td> <td style="text-align: center;"><input checked="" type="checkbox"/></td> <td style="text-align: center;"><input type="checkbox"/></td> <td style="text-align: center;"><input type="checkbox"/></td> </tr> <tr> <td>Cleaned ?</td> <td style="text-align: center;"><input checked="" type="checkbox"/></td> <td style="text-align: center;"><input type="checkbox"/></td> <td style="text-align: center;"><input type="checkbox"/></td> </tr> </tbody> </table>		no <sup>1)</sup>	yes	no	Was it in operation ?	<input type="checkbox"/>	<input type="checkbox"/>	<input checked="" type="checkbox"/>	Drained (product/operating supply item) ?	<input checked="" type="checkbox"/>	<input type="checkbox"/>	<input type="checkbox"/>	All openings hermetically locked!	<input checked="" type="checkbox"/>	<input type="checkbox"/>	<input type="checkbox"/>	Cleaned ?	<input checked="" type="checkbox"/>	<input type="checkbox"/>	<input type="checkbox"/>	<table border="1" style="width:100%; border-collapse: collapse;"> <thead> <tr> <th style="width:60%;"></th> <th style="width:10%; text-align: center;">no<sup>1)</sup></th> <th style="width:10%; text-align: center;">yes</th> </tr> </thead> <tbody> <tr> <td><b>Contamination :</b> toxic</td> <td style="text-align: center;"><input type="checkbox"/></td> <td style="text-align: center;"><input type="checkbox"/></td> </tr> <tr> <td>caustic</td> <td style="text-align: center;"><input type="checkbox"/></td> <td style="text-align: center;"><input type="checkbox"/></td> </tr> <tr> <td>inflammable</td> <td style="text-align: center;"><input type="checkbox"/></td> <td style="text-align: center;"><input type="checkbox"/></td> </tr> <tr> <td>explosive<sup>2)</sup></td> <td style="text-align: center;"><input type="checkbox"/></td> <td style="text-align: center;"><input type="checkbox"/></td> </tr> <tr> <td>mikrobiological<sup>2)</sup></td> <td style="text-align: center;"><input type="checkbox"/></td> <td style="text-align: center;"><input type="checkbox"/></td> </tr> <tr> <td>radioactive<sup>3)</sup></td> <td style="text-align: center;"><input type="checkbox"/></td> <td style="text-align: center;"><input type="checkbox"/></td> </tr> <tr> <td>other pollutant</td> <td style="text-align: center;"><input type="checkbox"/></td> <td style="text-align: center;"><input type="checkbox"/></td> </tr> </tbody> </table>		no <sup>1)</sup>	yes	<b>Contamination :</b> toxic	<input type="checkbox"/>	<input type="checkbox"/>	caustic	<input type="checkbox"/>	<input type="checkbox"/>	inflammable	<input type="checkbox"/>	<input type="checkbox"/>	explosive <sup>2)</sup>	<input type="checkbox"/>	<input type="checkbox"/>	mikrobiological <sup>2)</sup>	<input type="checkbox"/>	<input type="checkbox"/>	radioactive <sup>3)</sup>	<input type="checkbox"/>	<input type="checkbox"/>	other pollutant	<input type="checkbox"/>	<input type="checkbox"/>
	no <sup>1)</sup>	yes	no																																										
Was it in operation ?	<input type="checkbox"/>	<input type="checkbox"/>	<input checked="" type="checkbox"/>																																										
Drained (product/operating supply item) ?	<input checked="" type="checkbox"/>	<input type="checkbox"/>	<input type="checkbox"/>																																										
All openings hermetically locked!	<input checked="" type="checkbox"/>	<input type="checkbox"/>	<input type="checkbox"/>																																										
Cleaned ?	<input checked="" type="checkbox"/>	<input type="checkbox"/>	<input type="checkbox"/>																																										
	no <sup>1)</sup>	yes																																											
<b>Contamination :</b> toxic	<input type="checkbox"/>	<input type="checkbox"/>																																											
caustic	<input type="checkbox"/>	<input type="checkbox"/>																																											
inflammable	<input type="checkbox"/>	<input type="checkbox"/>																																											
explosive <sup>2)</sup>	<input type="checkbox"/>	<input type="checkbox"/>																																											
mikrobiological <sup>2)</sup>	<input type="checkbox"/>	<input type="checkbox"/>																																											
radioactive <sup>3)</sup>	<input type="checkbox"/>	<input type="checkbox"/>																																											
other pollutant	<input type="checkbox"/>	<input type="checkbox"/>																																											
If yes, with which cleaning agent: _____ and with which cleaning method: _____																																													
<sup>1)</sup> if "no", then forward to D.                      ← <sup>2)</sup> Aggregates, which are contaminated with microbiological or explosive substances, are only accepted with documented evidence of an approved cleaning. <sup>3)</sup> Aggregates, which are contaminated with radioactive substances, are not accepted in principle.																																													
<b>C. Details of the discharged materials (must be filled out imperatively)</b>																																													
<b>1. With which materials did the aggregate come into contact ?</b> Trade name and/or chemical designation of operational funds and discharged materials, material properties, e.g. as per safety data sheet (e.g. toxic, inflammable, caustic)																																													
<table border="1" style="width:100%; border-collapse: collapse;"> <thead> <tr> <th style="width:30%;"></th> <th style="width:30%; text-align: center;">no</th> <th style="width:30%; text-align: center;">yes</th> </tr> </thead> <tbody> <tr> <td>X Trade name: _____ Chemical designation: _____</td> <td style="text-align: center;"><input type="checkbox"/></td> <td style="text-align: center;"><input type="checkbox"/></td> </tr> <tr> <td>a) _____</td> <td style="text-align: center;"><input type="checkbox"/></td> <td style="text-align: center;"><input type="checkbox"/></td> </tr> <tr> <td>b) _____</td> <td style="text-align: center;"><input type="checkbox"/></td> <td style="text-align: center;"><input type="checkbox"/></td> </tr> <tr> <td>c) _____</td> <td style="text-align: center;"><input type="checkbox"/></td> <td style="text-align: center;"><input type="checkbox"/></td> </tr> <tr> <td>d) _____</td> <td style="text-align: center;"><input type="checkbox"/></td> <td style="text-align: center;"><input type="checkbox"/></td> </tr> </tbody> </table>			no	yes	X Trade name: _____ Chemical designation: _____	<input type="checkbox"/>	<input type="checkbox"/>	a) _____	<input type="checkbox"/>	<input type="checkbox"/>	b) _____	<input type="checkbox"/>	<input type="checkbox"/>	c) _____	<input type="checkbox"/>	<input type="checkbox"/>	d) _____	<input type="checkbox"/>	<input type="checkbox"/>																										
	no	yes																																											
X Trade name: _____ Chemical designation: _____	<input type="checkbox"/>	<input type="checkbox"/>																																											
a) _____	<input type="checkbox"/>	<input type="checkbox"/>																																											
b) _____	<input type="checkbox"/>	<input type="checkbox"/>																																											
c) _____	<input type="checkbox"/>	<input type="checkbox"/>																																											
d) _____	<input type="checkbox"/>	<input type="checkbox"/>																																											
<b>2. Are the materials specified above harmful to health ?</b> ←																																													
<b>3. Dangerous decomposition products during thermal load ?</b> ← <b>If yes, which ones ?</b>																																													

**D. Mandatory declaration:** We assure that the data in this explanation are truthful and complete and as a signatory I am able to form an opinion about this. We are aware that we are responsible towards the contractor for damages, which results from incomplete and incorrect data. We commit ourselves to exempt the contractor from claims for damages of thirds resulting from incomplete or incorrect data. We are aware that we are directly responsible towards thirds, irrespective of this declaration, which belongs in particularly to the employees of the contractor consigned with the handling repair of the product.

Name of the authorized person (in block letters): \_\_\_\_\_

\_\_\_\_\_ Date

\_\_\_\_\_ Signature

Company stamp

**FAX****Fax No. ()****Pages (incl. cover sheet) ()****To:**

()

Richter Chemie-Technik GmbH  
Otto-Schott-Straße 2  
D-47906 KempenTelefon +49 (0) 21 52/146-0  
Telefax +49 (0) 21 52/146-190richter-info@richter-ct.com  
www.richter-ct.comContact person:  
()Reference:  
()Extension:  
- ()E-Mail Address:  
()Date:  
()**Your order No.:** ()**Our Kom. No.:** ()**Serial No.:** ()

Dear Sirs,

The compliance with laws for the industrial safety obligates all commercial enterprises to protect their employees and/or humans and environment against harmful effects while handling dangerous materials.

The laws are such as: the Health and Safety at Work Act (ArbStättV), the Ordinance on Harzadous Substances (GefStoffV, BIOSTOFFV), the procedures for the prevention of accidents as well as regulations to environmental protection, e.g. the Waste Management Law (AbfG) and the Water Resources Act (WHG)

An inspection/repair of Richter products and parts will only take place, if the attached explanation is filled out correctly and completely by authorized and qualified technical personnel and is available.

In principle, radioactively loaded devices sent in, are not accepted.

Despite careful draining and cleaning of the devices, safety precautions should be necessary however, the essential information must be given.

The enclosed declaration of no objection is part of the inspection/repair order. Even if this certificate is available, we reserve the right to reject the acceptance of this order for other reasons.

Best regards  
RICHTER CHEMIE-TECHNIK GMBHEnclosures

()