



Rua do Progresso, lote 15
4760-841 Vilarinho das Cambas
V.N. Famalicão- Portugal



Tel: +351 252 303 210
www.vincovalves.com
comercial@vincovalves.com

**HYDROGEN
BALL VALVES**
FLOWING YOUR ENERGY

COMPANY



1 TECHNICAL INFORMATION 4-7

- General Features
- Fire Safe Design
- Fugitive Emissions
- Anti Explosive Decompression
- Hydrogen Embrittlement Resistance
- Cleanliness and Packing
- Contamination Free System

2 VALVES SERIES 8-21

INDUSTRIAL



FUELING



3 OPTIONS 22-23

- Lockable Handle
- Stem Extension
- Fire Fail Safe
- Double Block Bleed
- Bracket and Actuator
- Other Series

GENERAL FEATURES

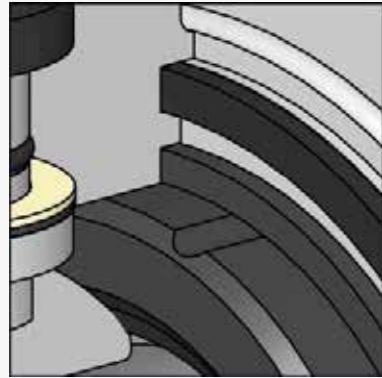

Double encapsulated body seals for extra resistance and tightness performance

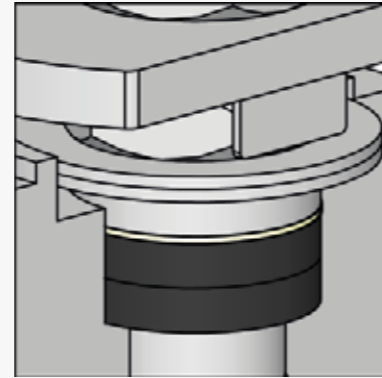

Self-adjust live loaded packing system ensures longer service without maintenance and spare parts replacement

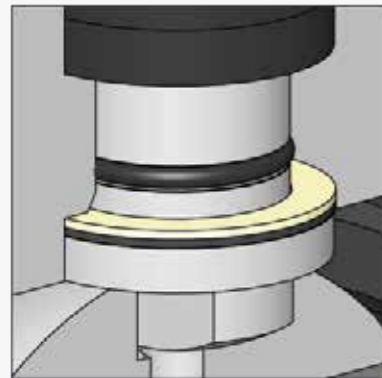

Anti-static device ensures the electrical conductivity between body, end, ball and stem according to European directive 2014/34/EU (ATEX)

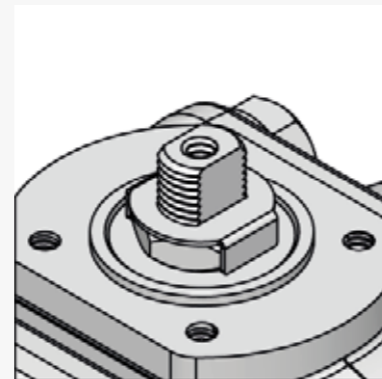

Top flange fitted with ISO 5211 providing universal connection for automation

FIRE SAFE DESIGN

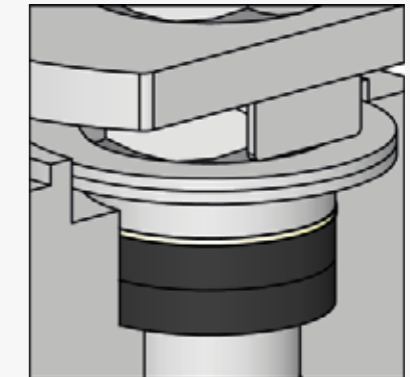
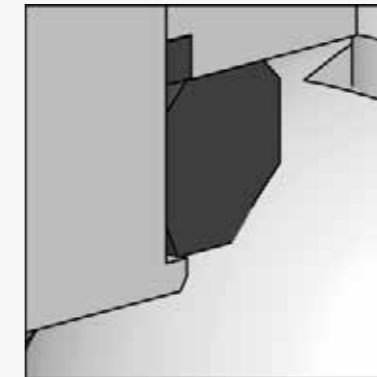
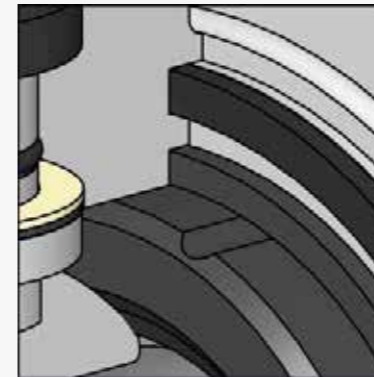

Firesafe design according to ISO 10497 and API 607 for critical services. Primary layer of TFE prevents graphite contamination into the media assuring the cleanliness of the processes. A metal backseat system allows the sealing in the event of a fire ensuring the tightness of the process.

FUGITIVE EMISSIONS

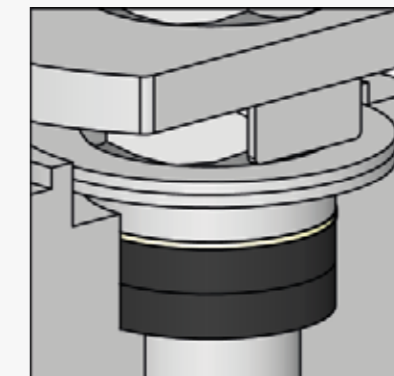
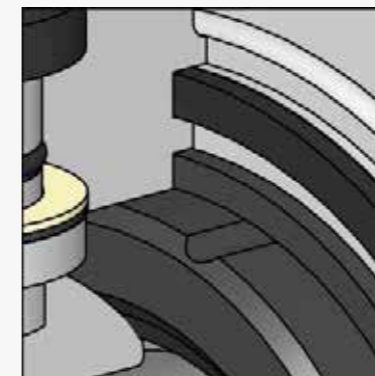

Fugitive emissions design according to ISO 15848 and TA LUFT / VDI 2440 reducing the potentially emission to the environment, the hydrogen losses and the risk of ignition.

ANTI EXPLOSIVE DECOMPRESSION

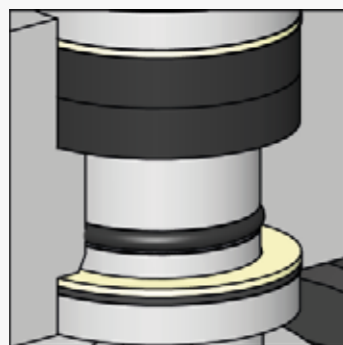

Explosive Decompression (ED) or Rapid Gas Decompression (RGD) is a failure mechanism associated with high pressure gas media. High pressure gas can reach easily the o-ring chambers. When the pressure is released, as when the valve is closed, the remaining gas located in the chamber expands causing fissures and o-ring failure.

The best solution to avoid this failure mechanism is the application of Anti Explosive Decompression (AED) o-rings. These o-rings applied in hydrogen valves are tested and certified in accordance with the requirements of norsok M-710 ensuring high safety levels.

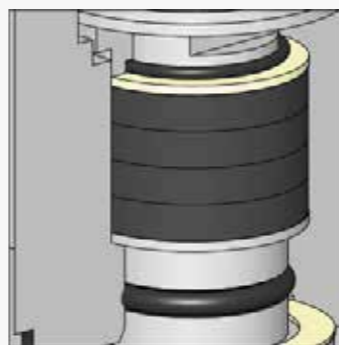

CONTAMINATION FREE SYSTEM

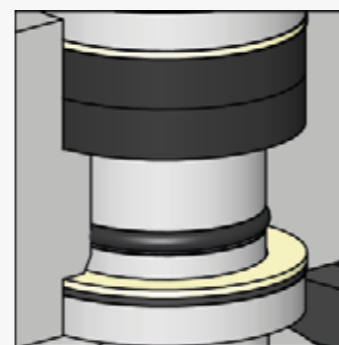

High purity hydrogen is an important requirement in some processes to guarantee high levels of quality and process performance and efficiency while keeping the valve with the firesafe safe design. To perform this the valves are designed with double insulation system where the first line is made from inert polymeric materials isolating the hydrogen media from any contact with graphite parts. This design is capable to avoid any contamination ensuring the high purity levels of the processes.

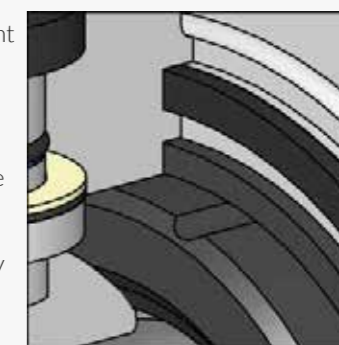

HYDROGEN EMBRITTLEMENT RESISTANCE

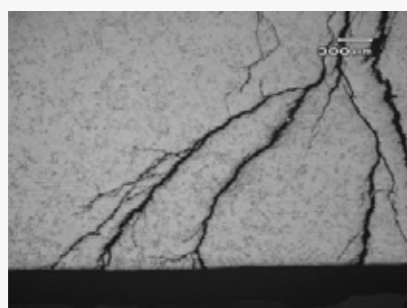

The metallic pressure retaining and wetted parts are stainless steel ensuring high levels of hydrogen embrittlement resistance.

OPTIONAL CLEANLINESS AND PACKING



The valves can be degreased to achieve high levels of cleanliness and prevent hydrogen autoignition in service. Afterwards this the valves are packed and sealed in individual protective plastic bags with silica to prevent contamination and humidity problems.

CERTIFICATION

CONSTRUCTION STANDARDS

TEST STANDARDS

Fuelling Stations Certification acc. to ISO 19880-3 (intended process)

CE Certification acc. to TPED 2010/35/EU (intended process)

CE Certification acc. to PED 2014/68/EU

Fire Safe Design acc to API 607 Ed.6 / ISO 10497

CE Certification acc. to ATEX II 2GD 2014/34/EU

Company Quality System Certified acc. to ISO 9001

ASME B16.34

ISO 17292-1

ASME B16.25 & B36.10M

ASME B16.11

ASME B1.20.1

ISO 7.1

ISO 19 880-3

Test applied:

Hydrostatic shell and seat test

Pneumatic shell and seat test

Helium Test

Available Upon Request

EN 10204 type 3.1 certificate is available for each valve

CFH Series

2 Way Floating
Investment Cast

The CFH Series is a cast floating ball valve specifically designed for industrial hydrogen applications up to PN40 (40 bar / 4 MPa). Concerning the high flammability of the hydrogen, the design includes some important considerations about safety, low emissions, internal tightness and contamination issues. These requirements are achieved through a special design of the sealing systems with the inclusion of a double insulation layer. The first layer is composed of polymeric materials and the secondary by expanded graphite. The first layer ensures high levels of tightness and prevents any contamination with small particles that may be released by the graphite seals. On the other hand, graphite layers are the best solution to increase the tightness capabilities and to provide the firesafe design increasing the safety and the quality of the solution. In addition, the packing system is equipped with a RGD o-ring to prevent failures due to high decompressions which may lead to massive leakage and hydrogen contamination on the line. These combined solution helps providing clean hydrogen to the applications by ensuring high levels of safety, low emissions, internal tightness and no contamination. It is available with welding or threaded connections making this series the best solutions for industrial low pressure systems.

DIN PN 16 / 40

Full Bore: DN15 - 200

INDUSTRIAL RANGE

DESIGN TEMPERATURE

-50°C to 240°C

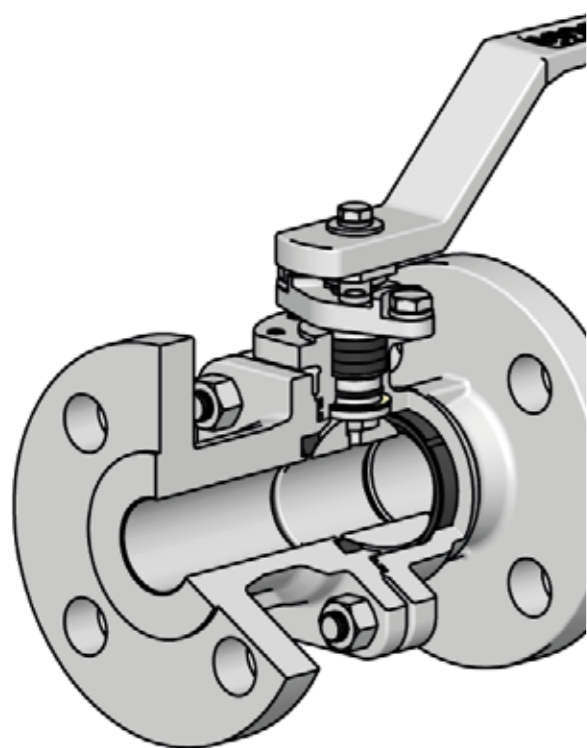
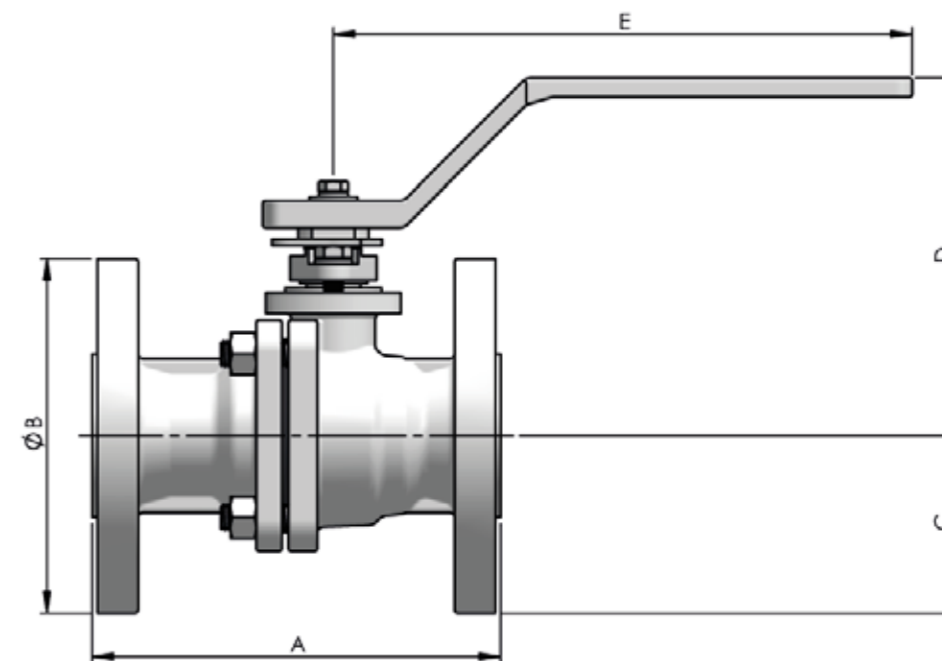

PART	STANDARD	
	CARBON STEEL	STAINLESS STEEL
Body / Ends	1.0619	1.4408
TRIM	Ball	1.4408
	Stem	1.4401 / 4
Seats	C-RPTFE	
O'ring	FKM AED	
Packing & Seals	C-RPTFE & Graphite	
Bolting	Gr 8.8	A4 CL70

DN	PN	BORE	A			B	C	D	E	ISO 5211
			F1	F4	F5					
65	16	62	290	170	-	185	92.5	185	360	F07
80	16	75	310	180	-	200	100	200	360	F10
100	16	100	350	190	-	220	110	235	480	F10
150	16	150	-	-	350	300	150	GEAR		F14
200	16	201	-	-	400	430	215	GEAR		F16

DN	PN	BORE	A		B	C	D	E	ISO 5211
			F1	F4					
15	40	15.1	130	115	95	47.5	95	150	F04
20	40	20.6	150	120	105	52.5	105	180	F04
25	40	25.4	160	125	115	57.5	110	180	F04
32	40	31.8	180	130	140	70	130	210	F05
40	40	38.1	200	140	150	75	135	210	F05
50	40	49	230	150	165	82.5	165	300	F07
65	40	62	290	170	185	92.5	185	360	F07
80	40	75	310	180	200	100	200	360	F10
100	40	00	350	190	235	117.5	235	480	F10

CFH Series

2 Way Floating
Investment Cast

The CFH Series is a cast floating ball valve specifically designed for industrial hydrogen applications up to CL300 (750 psi / 4.9 MPa). Concerning the high flammability of the hydrogen, the design includes some important considerations about safety, low emissions, internal tightness and contamination issues. These requirements are achieved through a special design of the sealing systems with the inclusion of a double insulation layer. The first layer is composed of polymeric materials and the secondary by expanded graphite. The first layer ensures high levels of tightness and prevents any contamination with small particles that may be released by the graphite seals. On the other hand, graphite layers are the best solution to increase the tightness capabilities and to provide the firesafe design increasing the safety and the quality of the solution. In addition, the packing system is equipped with a RGD o-ring to prevent failures due to high decompressions which may lead to massive leakage and hydrogen contamination on the line. These combined solution helps providing clean hydrogen to the applications by ensuring high levels of safety, low emissions, internal tightness and no contamination. It is available with welding or threaded connections making this series the best solutions for industrial low pressure systems.

ASME CL 150 / 300

Full Bore: ½" - 8"

INDUSTRIAL RANGE

DESIGN TEMPERATURE

-50°C to 240°C

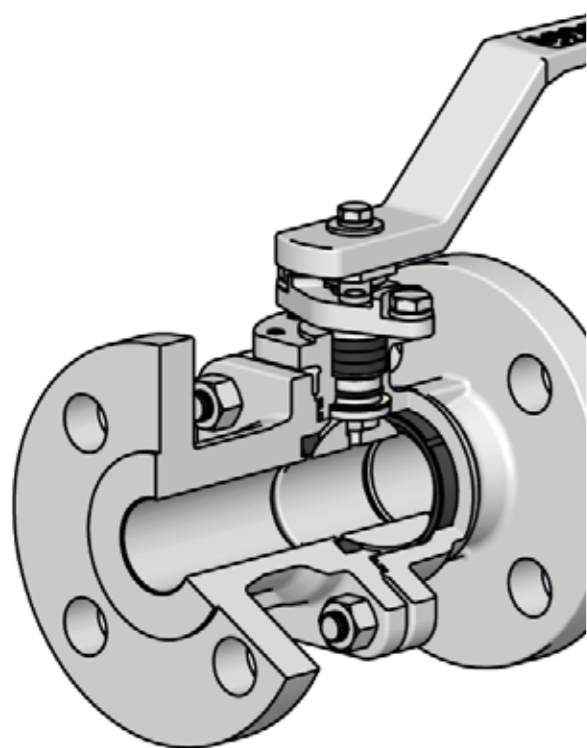

PART	STANDARD	
	CARBON STEEL	STAINLESS STEEL
Body / Ends	A216 WCB	A351 CF8M
TRIM	Ball	A351 CF8M
	Stem	A479 316/L
Seats	C-RPTFE	
O'ring	FKM AED	
Packing & Seals	C-RPTFE & Graphite	
Bolting	A193 Gr. B7	A193 Gr. B8M cl.2

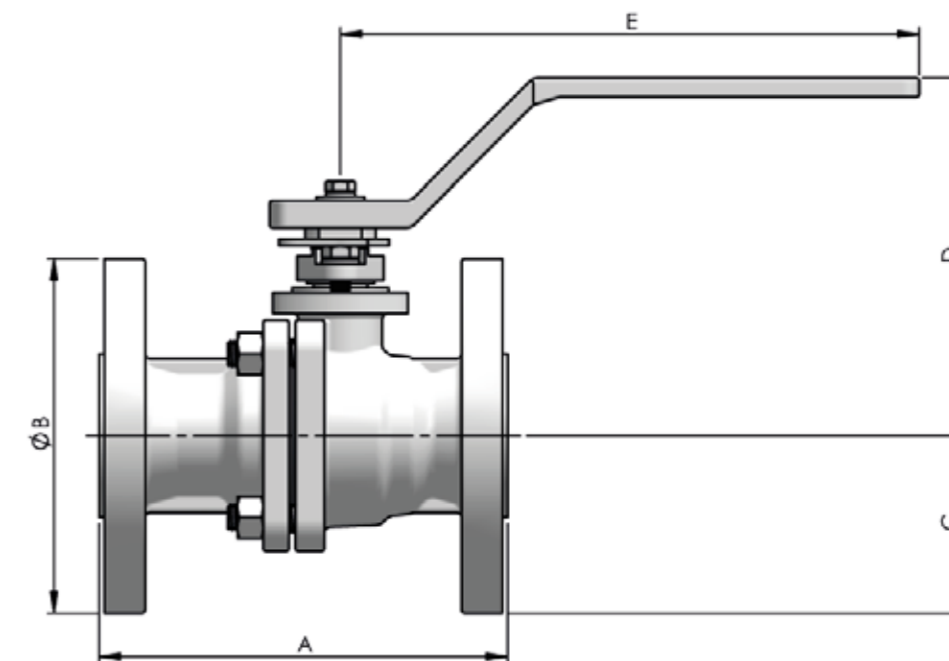

DN	CLASS	BORE	A	B	C	D	E	kg	ISO 5211
½"	150	15.1	108	90	45	95	150	1.8	F04
¾"	150	20.6	117	100	50	105	180	2.7	F04
1"	150	25.4	127	110	55	110	180	3.5	F04
1½"	150	38.1	165	125	62.5	135	210	6.5	F05
2"	150	49	178	150	75	165	300	12	F07
2½"	150	62	190	180	90	185	360	18	F07
3"	150	75	203	190	95	200	360	24.5	F10
4"	150	100	229	230	115	235	480	40	F10
6"	150	150	394	280	140	GEAR		120	F14
8"	150	201	457	345	172.5	GEAR		220	F16

DN	CLASS	BORE	A	B	C	D	E	kg	ISO 5211
½"	300	15.1	140	95	47.5	95	150	2.3	F04
¾"	300	20.6	152	115	57.5	105	180	3.7	F04
1"	300	25.4	165	125	62.5	110	180	5	F04
1½"	300	38.1	190	155	77.5	135	210	9.5	F05
2"	300	49	216	165	82.5	165	300	14	F07
2½"	300	62	241	190	95	185	360	21	F07
3"	300	75	282	210	105	200	360	31	F10
4"	300	100	305	255	127.5	235	480	53	F10
6"	300	150	403	320	160	GEAR		145	F14
8"	300	201	502	380	190	GEAR		270	F16

XFH Series

2 Way Floating
Investment Cast

The XFH Series is a cast floating ball valve specifically designed for industrial hydrogen applications up to CL600 (1500 psi / 9.9 MPa). Concerning the high flammability of the hydrogen, the design includes some important considerations about safety, low emissions, internal tightness and contamination issues. These requirements are achieved through a special design of the sealing systems with the inclusion of a double insulation layer. The first layer is composed of polymeric materials and the secondary by expanded graphite. The first layer ensures high levels of tightness and prevents any contamination with small particles that may be released by the graphite seals. On the other hand, graphite layers are the best solution to increase the tightness capabilities and to provide the firesafe design increasing the safety and the quality of the solution. In addition, the packing system is equipped with a RGD o-ring to prevent failures due to high decompressions which may lead to massive leakage and hydrogen contamination on the line. These combined solution helps providing clean hydrogen to the applications by ensuring high levels of safety, low emissions, internal tightness and no contamination. It is available with welding or threaded connections making this series the best solutions for industrial low pressure systems.

ASME CL 300 / 400 / 600

Full Bore: 3/8" - 4"

Reduced Bore: 1/2" - 4"

INDUSTRIAL RANGE

DESIGN TEMPERATURE

-50°C to 240°C

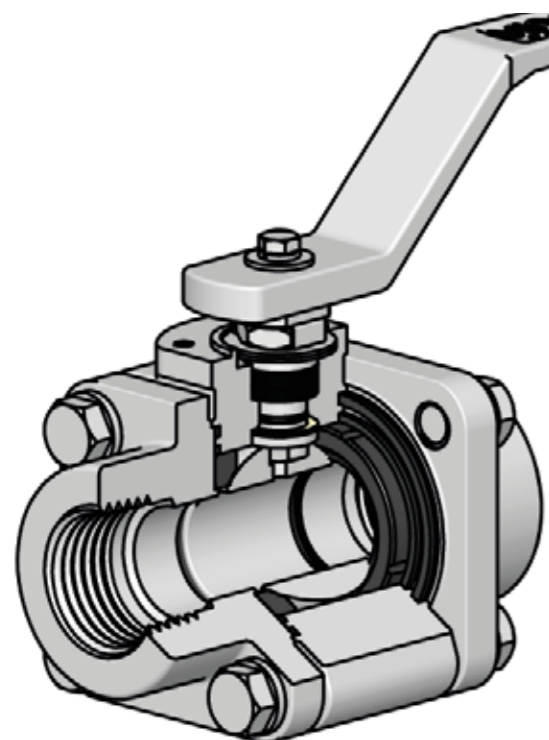
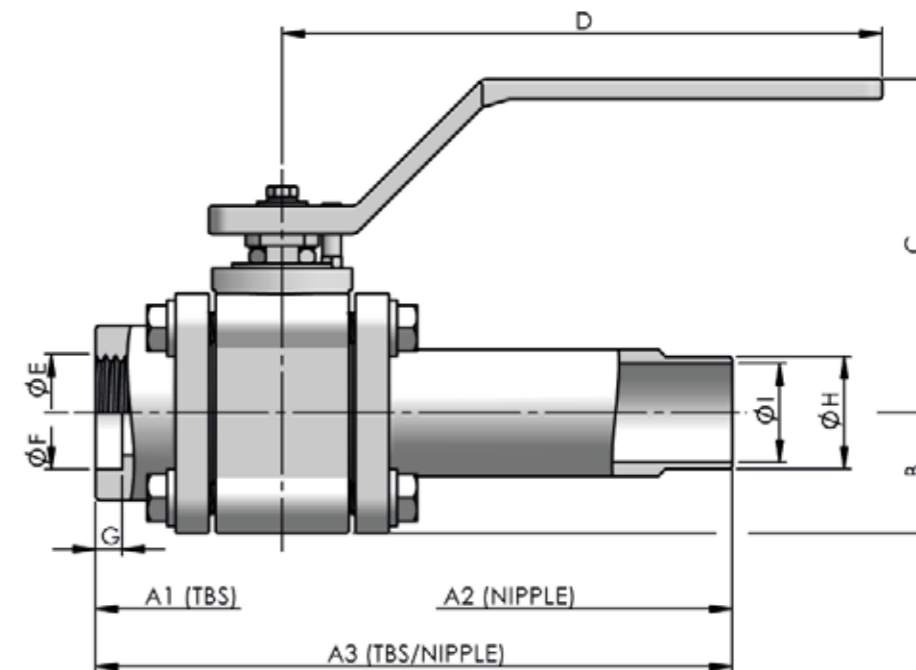

PART	STANDARD	
	CARBON STEEL	STAINLESS STEEL
Body / Ends	A216 WCB	A351 CF3M
TRIM	Ball	A351 CF8M
	Stem	A479 316/L
Seats	C-RPTFE	
O'ring	FKM AED	
Packing & Seals	C-RPTFE & Graphite	
Bolting	A193 Gr. B7	A193 Gr. B8M cl.2

DN	CLASS	BORE	A1	A2	A3	B	C	D	E	F	G	H	I	kg	ISO 5211		
3/8"	600	11.9	70	-	-	24	75	150	NPT / BSPT SW BW & BW Nipple								
1/2"	600	15.1	75	250	162.5	26.5	80	150								1	F03
3/4"	600	20.6	90	260	175	32.5	95	180								1.2 / 1.6	F03
1"	600	25.4	100	270	185	36	100	180								2 / 2.5	F04
1 1/4"	600	31.8	115	280	197.5	43	120	210								3 / 3.5	F04
1 1/2"	600	38.1	125	290	207.5	48	125	210								4.5 / 6	F05
2"	600	49	165	310	237.5	72	145	300								6 / 7	F05
2 1/2"	400	62	190	330	260	87	175	360								10.5 / 11.5	F07
3"	400	75	215	350	282.5	97	190	360								17.5 / 19	F07
4"	300	100	265	390	327.5	122	230	480								25.5 / 26.5	F10
														45 / 47	F10		

SFH Series

2 Way Floating
Forging

The SFH Series is a forged floating ball valve specifically designed for industrial hydrogen applications up to CL800 (136 bar / 13.6 MPa). Concerning the high flammability of the hydrogen, the design includes some important considerations about safety, low emissions, internal tightness and contamination issues. These requirements are achieved through a special design of the sealing systems with the inclusion of a double insulation layer. The first layer is composed of polymeric materials and the secondary by expanded graphite. The first layer ensures high levels of tightness and prevents any contamination with small particles that may be released by the graphite seals. On the other hand, graphite layers are the best solution to increase the tightness capabilities and to provide the firesafe design increasing the safety and the quality of the solution. In addition, the packing system is equipped with a RGD o'ring to prevent failures due to high decompressions which may lead to massive leakage and hydrogen contamination of the line. These combined solution help providing clean and true green hydrogen to the applications by ensuring high levels of safety, low emissions, internal tightness and no contamination. It is available with welding or threaded connections making this series the best solutions for compact and permanent systems.

ASME CL 800

Full Bore: ½" - 1½"

Reduced Bore: ¾" - 2"

INDUSTRIAL RANGE

DESIGN TEMPERATURE

-50°C to 240°C

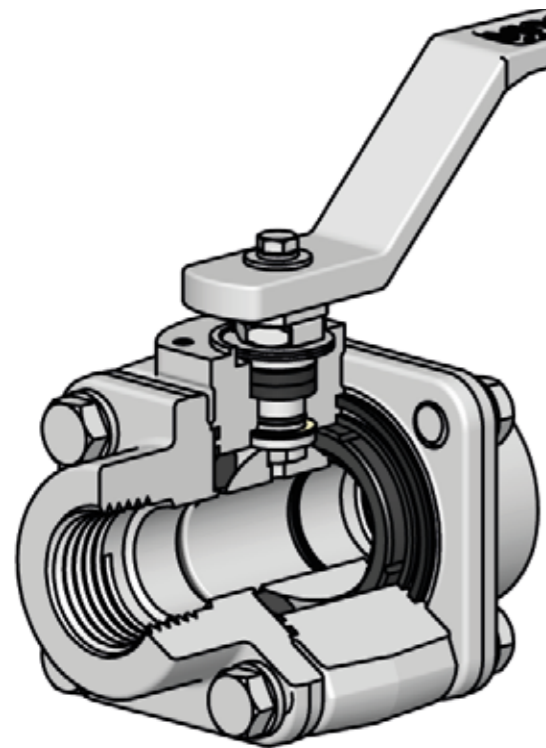
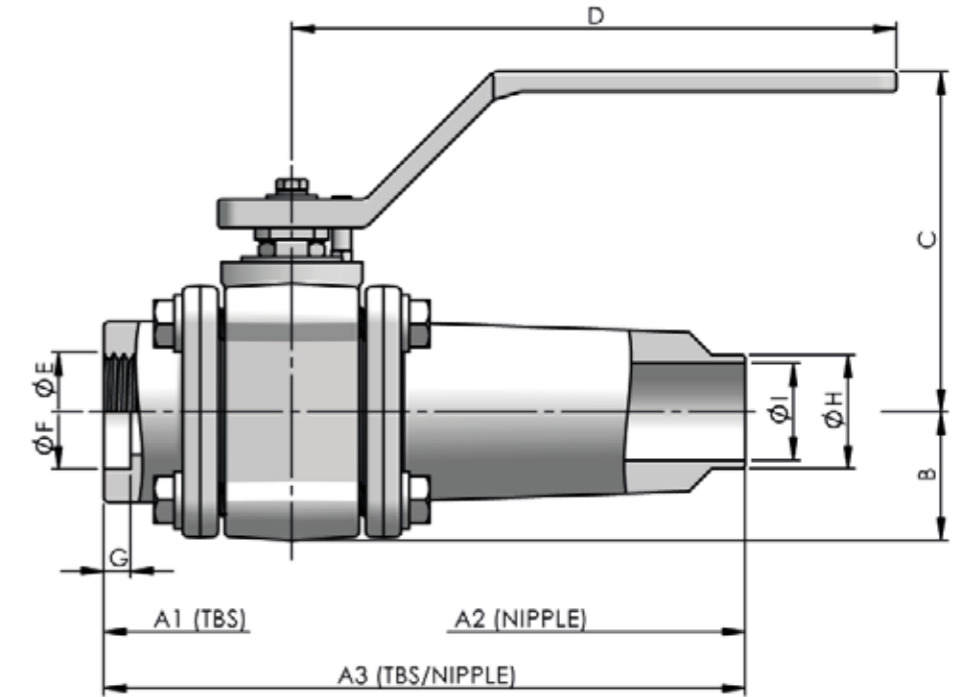

PART	STANDARD	
	CARBON STEEL	STAINLESS STEEL
Body / Ends	A105 N / A350 LF2 cl.1	A182 F316/L
TRIM	Ball	A351 CF8M
	Stem	A479 316/L
Seats	C-RPTFE	
O'ring	FKM AED	
Packing & Seals	C-RPTFE & Graphite	
Bolting	A193 Gr. B7	A193 Gr. B8M cl.2

DN	CLASS	BORE	A1	A2	A3	B	C	D	E	F	G	H	I	kg	ISO 5211
½"	800	15.1	75	250	162.5	27.5	80	150	NPT / BSPT SW BW & BW Nipple					1.5 / 2.5	F03
¾"	800	20.6	90	260	175	33.5	95	180						2.5 / 3.5	F04
1"	800	25.4	100	270	185	37	100	180						3 / 5	F04
1¼"	800	31.8	115	-	-	44	120	210						5	F05
1½"	800	38.1	125	290	207.5	49	125	210						7 / 9	F05

HFH Series

2 Way Floating
Barstock / Forging

The HFH Series is a barstock floating ball valve specifically designed for hydrogen fueling applications up to CL1500 (3600 psi / 24.8 MPa). Concerning the high flammability of the hydrogen, the design includes some important considerations about safety, low emissions, internal tightness and contamination issues. These requirements are achieved through a special design of the sealing systems with the inclusion of a double insulation layer. The first layer is composed of polymeric materials and the secondary by expanded graphite. The first layer ensures high levels of tightness and prevents any contamination with small particles that may be released by the graphite seals. On the other hand, graphite layers are the best solution to increase the tightness capabilities and to provide the firesafe design increasing the safety and the quality of the solution. In addition, the packing system is equipped with a RGD o'ring to prevent failures due to high decompressions which may lead to massive leakage and hydrogen contamination on the line. These combined solution helps providing clean hydrogen to the applications by ensuring high levels of safety, low emissions, internal tightness and no contamination. It is available with welding or threaded connections making this series the best solutions for high pressure fueling systems.

ASME CL1500

Full Bore: ½" - 1½"
Reduced Bore: ¾" - 2"

FUELING RANGE

DESIGN TEMPERATURE

-50°C to 280°C

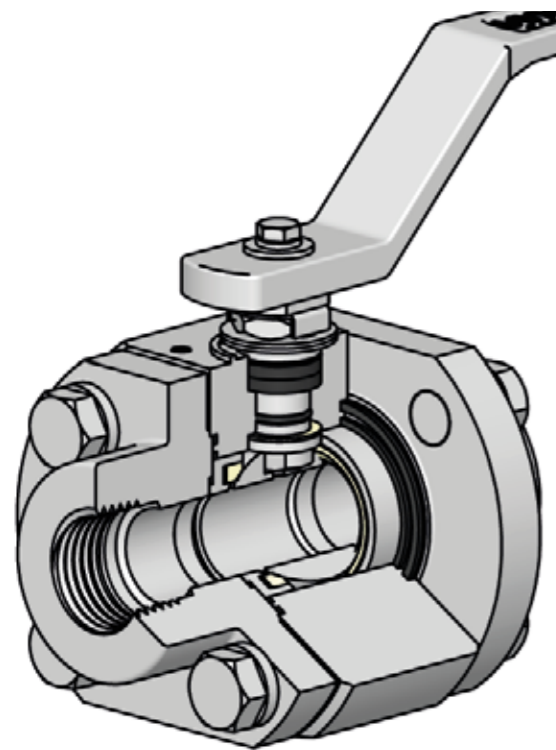
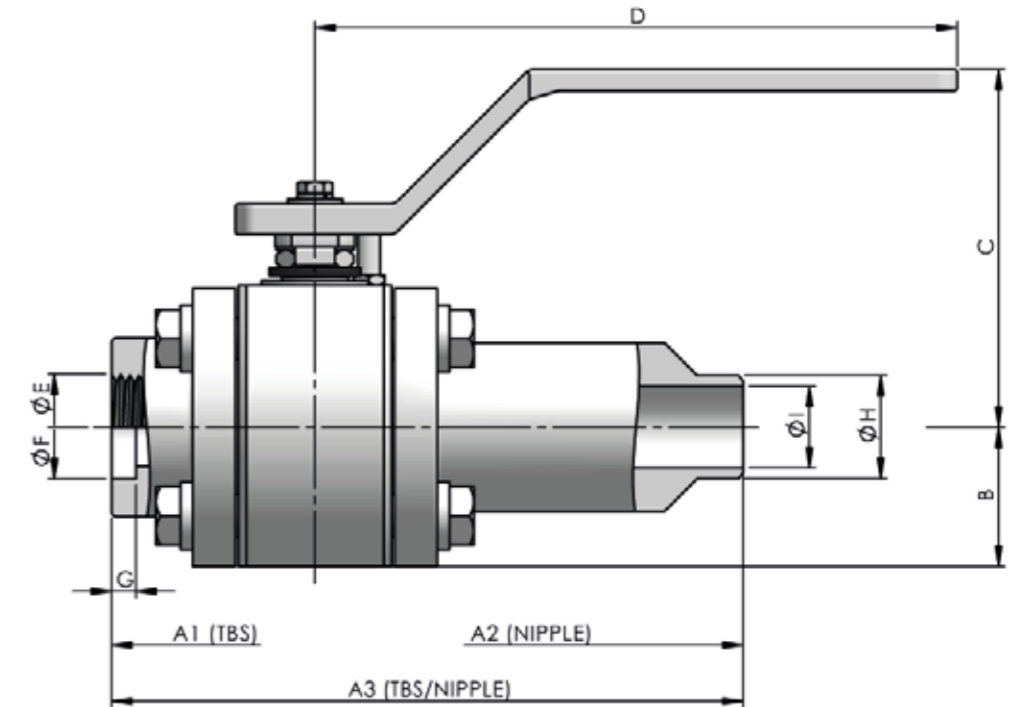

PART		STANDARD STAINLESS STEEL
Body / Ends		A479 316/L
TRIM	Ball	HS. ST. ST.
	Stem	HS. ST. ST.
Seats		PEEK
O'ring		FKM AED
Packing & Seals		C-RPTFE & Graphite
Bolting		A193 Gr. B8M cl.2

DN	CLASS	BORE	A1	A2	A3	B	C	D	E	F	G	H	I	kg	ISO 5211
½"	1500	15.1	90	260	175	33.5	95	180	NPT / BSPT SW BW & BW Nipple					3 / 4	F04
¾"	1500	20.6	105	270	187.5	37	100	180						4 / 6	F04
1"	1500	25.4	120	280	200	45.5	115	210						7 / 9	F05
1¼"	1500	31.8	140	290	-	55.5	125	210						10 / 13	F05
1½"	1500	38.1	160	305	232.5	66.5	140	300						15.5 / 19.5	F07

HFH Series

2 Way Floating
Barstock / Forging

The HFH Series is a barstock floating ball valve specifically designed for hydrogen fueling applications up to CL2500 (6000 psi / 41.3 MPa). Concerning the high flammability of the hydrogen, the design includes some important considerations about safety, low emissions, internal tightness and contamination issues. These requirements are achieved through a special design of the sealing systems with the inclusion of a double insulation layer. The first layer is composed of polymeric materials and the secondary by expanded graphite. The first layer ensures high levels of tightness and prevents any contamination with small particles that may be released by the graphite seals. On the other hand, graphite layers are the best solution to increase the tightness capabilities and to provide the firesafe design increasing the safety and the quality of the solution. In addition, the packing system is equipped with a RGD o'ring to prevent failures due to high decompressions which may lead to massive leakage and hydrogen contamination on the line. These combined solution helps providing clean hydrogen to the applications by ensuring high levels of safety, low emissions, internal tightness and no contamination. It is available with welding or threaded connections making this series the best solutions for very high pressure fueling systems.

ASME CL2500
Standard Bore: ½" - 1"

FUELING RANGE

DESIGN TEMPERATURE
-50°C to 280°C

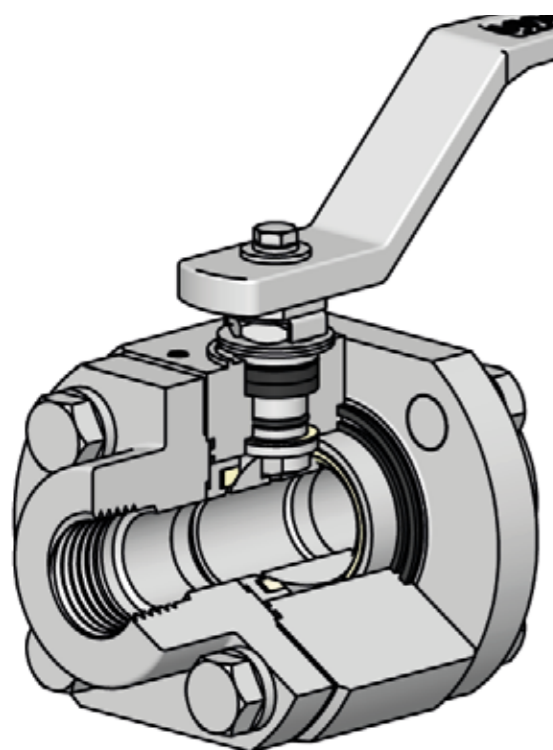
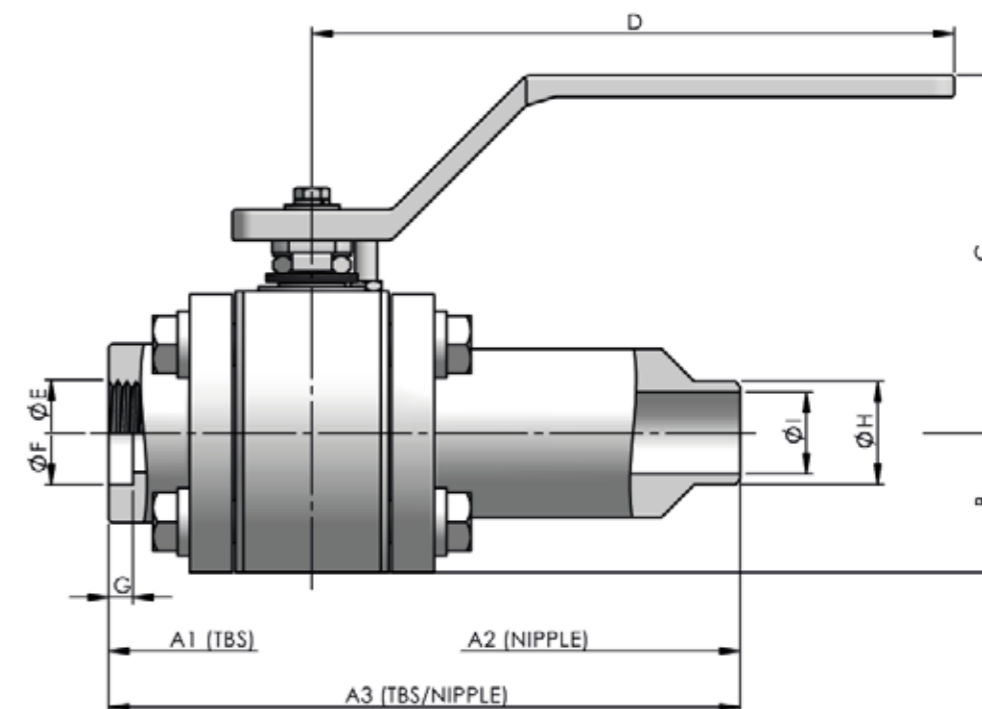

PART		STANDARD STAINLESS STEEL
Body / Ends		A479 316/L
TRIM	Ball	HS. ST. ST.
	Stem	HS. ST. ST.
Seats		PEEK
O'ring		FKM AED
Packing & Seals		C-RPTFE & Graphite
Bolting		A193 Gr. B8M cl.2

DN	CLASS	BORE	A1	A2	A3	B	C	D	E	F	G	H	I	kg	ISO 5211
½"	2500	11.9	90	260	175	33.5	80	150	NPT / BSPT					2.5 / 4	F03
¾"	2500	15.1	105	270	187,5	37	95	180	SW					4 / 6	F04
1"	2500	20.6	120	280	200	45.5	105	180	BW & BW Nipple					6.5 / 9	F04

HFH Series

2 Way Floating
Barstock / Forging

The HFH Series is a barstock floating ball valve specifically designed for hydrogen fueling applications up to CL4000 (10000 psi / 68.9 MPa). Concerning the high flammability of the hydrogen, the design includes some important considerations about safety, low emissions, internal tightness and contamination issues. These requirements are achieved through a special design of the sealing systems with the inclusion of a double insulation layer. The first layer is composed of polymeric materials and the secondary by expanded graphite. The first layer ensures high levels of tightness and prevents any contamination with small particles that may be released by the graphite seals. On the other hand, graphite layers are the best solution to increase the tightness capabilities and to provide the firesafe design increasing the safety and the quality of the solution. In addition, the packing system is equipped with a double RGD o'ring to prevent failures due to high decompressions which may lead to massive leakage and hydrogen contamination on the line. These combined solution helps providing clean hydrogen to the applications by ensuring high levels of safety, low emissions, internal tightness and no contamination. It is available with welding or threaded connections making this series the best solutions for ultra high pressure fueling systems.

ASME CL4000
Standard Bore: ½" - 1"

FUELING RANGE

DESIGN TEMPERATURE
-50°C to 280°C

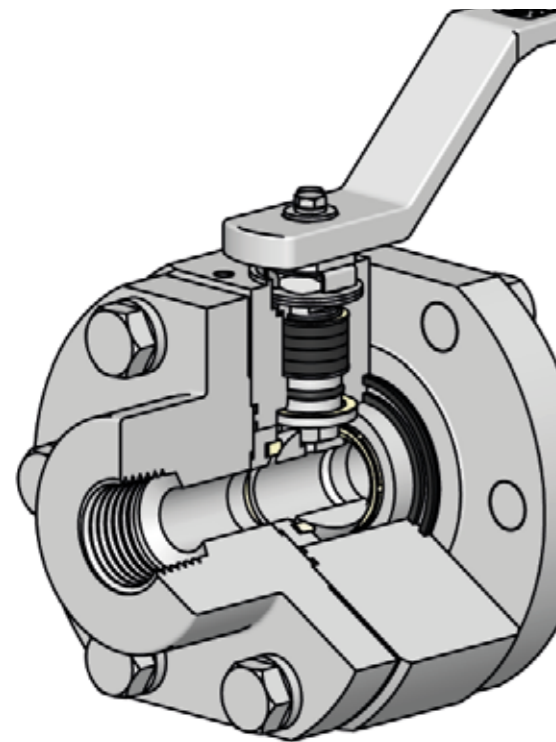
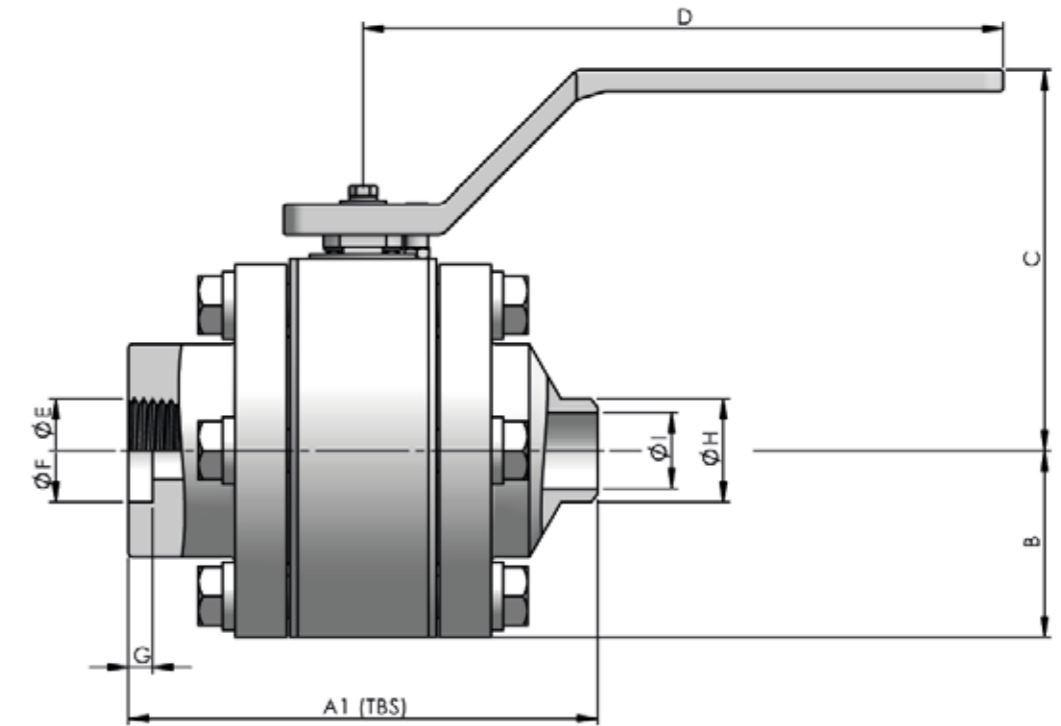

PART		STANDARD STAINLESS STEEL
Body / Ends		A479 316/L
TRIM	Ball	HS. ST. ST.
	Stem	HS. ST. ST.
Seats		PEEK
O'ring		FKM AED
Packing & Seals		C-RPTFE & Graphite
Bolting		A193 Gr. B8M cl.2

DN	CLASS	BORE	A1	B	C	D	E	F	G	H	I	kg	ISO 5211
½"	4000	9	110	40	90	150	NPT / BSPT				5	F04	
¾"	4000	13	125	45.5	105	180	SW				7	F04	
1"	4000	19	140	61	125	210	BW				11.5	F05	

MANUAL OPERATION

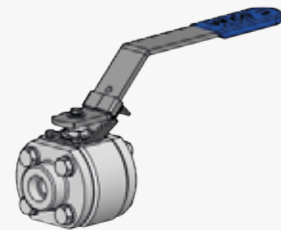

LOCKABLE HANDLE

The lockable handle is a safety device that prevents the unintended rotation of the obturator due to vibrations, turbulent flows or unauthorized actions leading to potentially severe malfunctions in the process. This occurrence can be prevented by the application of a lockable mechanism to prevent the valve from closing or opening. Small sizes are equipped with a trigger that allows to lock the position of the handle in closed or open position without the need of a padlock. Nevertheless, all sizes can be equipped with a padlock.

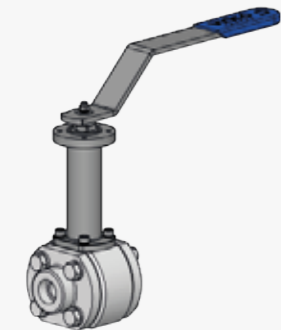

STEM EXTENSION

Inaccessible locations, insulation of the piping, extreme temperatures and others are usually conditions found in several processes where easier operation solutions are required. In these kind of applications, a stem extension can be the solution to decrease the restrictions and insure the safe operation of the processes. The standard stem extension is equipped with a secondary stem packing system containing eventual emissions to the atmosphere. Other options are also available upon request.



OVAL HANDLE

The standard handle is sometimes too long to fit in tiny spaces that are available for the valves in a process. An oval handle could be the best way to reduce the size of the valve without losing the operation capabilities. This solution strongly decreases the surrounding space needed for each valve improving the compactness of the installation.

AUTOMATIC OPERATION

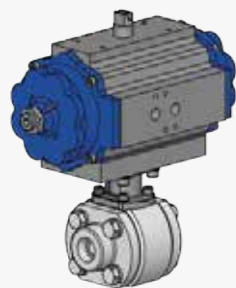

BRACKET AND ACTUATOR

Automation of the processes is a growing and necessary investment to reduce the manual interventions, which will prevent the eventual mistakes by a manual operation and enhance the processes to better performances. Following these requirements, the valves can also be fully automated. For instance, the valve can be equipped with a pneumatic actuator, a solenoid valve and a limit switch. These accessories will allow the remote actuation of the valve and the control of its position.

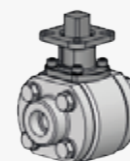

SPECIFIC APPLICATIONS

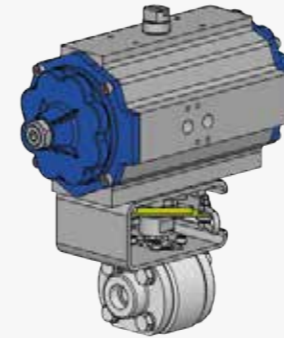

FIRE FAIL SAFE

Flammable gases and chemicals are often used in processes across several industries. To prevent the widespread of a fire event in these facilities, a fire fail safe valve may be used as a safety device, which will trigger an automatic emergency shutoff. The fire fail safe valve is designed to be activated at the set temperature of the system by the fusible link breakage. This breakage will lead to the line shutoff.

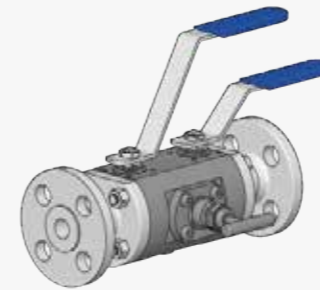

DOUBLE BLOCK AND BLEED

Some processes require repetitive sampling for analysis to guarantee high quality levels of the process products. The best way to achieve this is the installation of a DBB valves. This kind of valves consists of two ball valves used to trap the fluid and a middle valve used to extract the sample. With this kind of valves, usually applied as a forked section, it is possible to trap and remove a sample from the system without stopping the process. This valve type is also frequently used for instrumentation protection.

SPECIAL SERVICE

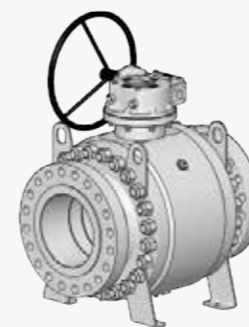

TRUNNION DESIGN

Severe service or higher sizes demands special design to achieve high levels of quality and safety insurance. The trunnion version is the best solution to improve reliability and the life time of the valve without maintenance due to its unique seat design and ball fixation. These features reduces the misalignment, extra torque and wear when compared with floating version.