

Spindle axes ELGC-BS-KF

FESTO



This drive is also available as a product unit as part of the
Simplified Motion Series
Spindle axis ELGS-BS-KF



Characteristics

At a glance



- Optimal installation space to working space ratio
- Protected against external influences by internal guide
- Unique assembly system
- Compact double bearing integrated in the axis to save space
- Stainless steel cover strip kept in place with magnetic strips
- Wide range of mounting options for optimum machine integration

Compact

Optimum dimensions thanks to the integrated compact coupling and a very short slide

Flexible

Adapterless combination of ELGC and EGSC using the innovative "one size down" assembly system

Integrated

Simple position sensing with proximity switch SMT-8M and integrated positioning magnet

Protected

The cover strip and the optional vacuum connection provide protection against particle immissions and emissions

Modular and flexible with motor, motor mounting kit and servo drive

Motor

Servo motor



Stepper motor



Servo drive

Servo drive



Motor controller for stepper motor



Motor mounting kit

Axial kit



Parallel kit

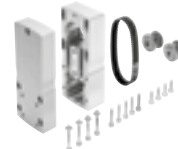

Simplicity in one unit

This product is also available as a product unit as part of the Simplified Motion Series:



- The Simplified Motion Series combines the simplicity of pneumatics with the benefits of electric automation. The perfect solution for all users who are looking for an electric alternative for very simple movement and positioning tasks, but don't want the commissioning process for traditional electric drive systems that can often be quite complex.
- Simplified functionality for simple movements between two end positions
- A variety of movements with different mechanical systems
- Integrated products eliminate the need for a control cabinet
- Quick and easy commissioning without software or special expertise
- Digital I/O and IO-Link integrated as standard

Characteristics

From the individual axis to the complete handling system



- The toothed belt and spindle axes ELGC and mini slide EGSC form a scalable modular system for compact automation
- The shared platform architecture creates a consistent range with matching interfaces. A large number of systems can be realised entirely without adapter plates
- Powerful drive and guide components ensure a long service life, as well as excellent load capacity and reliability
- The uniform and universal range of accessories reduces warehousing and design costs
- Two position sensing functions can be selected:
 - With magneto-resistive proximity switches (detection via integrated magnets)
 - With inductive proximity switches (detection via switch lug)

The products for the handling system

Spindle axis
ELGC-BS



Toothed belt axis
ELGC-TB



Guide axis
ELFC



Mini slide
EGSC



Typical handling systems

For applications where compact dimensions are essential, the axes ELGC can be combined into very space-saving handling systems that are suitable for assembly systems, test and inspection systems, small parts handling, the electronics industry and desktop applications. The very compact linear axes ELGC, mini slide EGSC and electric cylinder EPCC offer an optimal ratio between installation space and working space. They feature a common system approach and platform architecture and the connections are largely adapterless.

Cantilever system

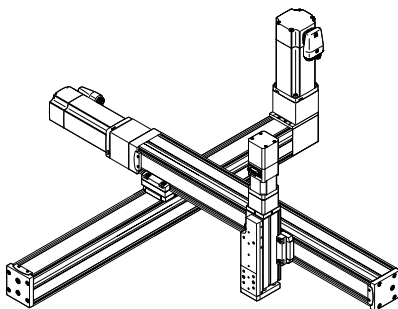

Planar surface gantry

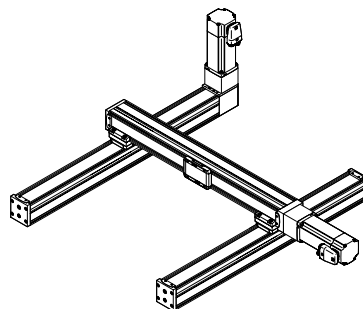

3-dimensional gantry

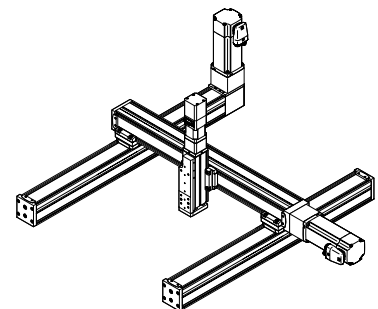

Characteristics

Matrix showing combinations between axis ELGC/ELGS-TB, ELGC/ELGS-BS, mini slide EGSC/EGSS-BS, electric cylinder EPCC/EPCS-BS and guide axis ELFC
Mounting options with profile mounting and via angle kit

	Size	Assembly axis ELGC-BS/-TB; ELFC; EGSC-BS; EPCC-BS; ELGS-BS/-TB; EGSS-BS, EPCS-BS			
		25	32	45	60
Base axis	32	■	–	–	–
ELGC-BS/-TB; ELFC;	45	–	■	–	–
ELGS-BS/-TB	60	–	–	■	–
	80	–	–	–	■

With profile mounting EAHF-L2-...-P-D...

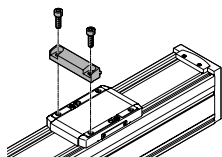

- Mounting option: base axis with one-size-down assembly axis

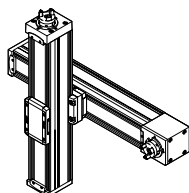
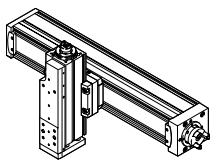

With angle kit EHAA-D-L2-...-AP

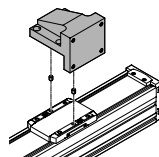

- Mounting option: base axis rotated through 90° with one-size-down assembly axis

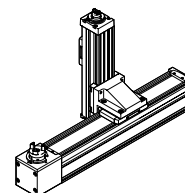
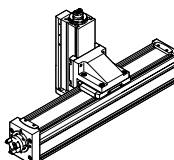

Matrix showing combinations between axis ELGC/ELGS-TB, ELGC/ELGS-BS, mini slide EGSC/EGSS-BS, electric cylinder EPCC/EPCS-BS and guide axis ELFC
Assembly options with adapter kit or direct mounting

	Size	Assembly axis ELGC-BS/-TB; ELFC; EGSC-BS; EPCC-BS; ELGS-BS/-TB; EGSS-BS, EPCS-BS				
		25	32	45	60	80
Base axis	32	■	–	–	–	–
ELGC-BS/-TB; ELFC;	45	–	■	–	–	–
ELGS-BS/-TB	60	–	–	■	–	–
	80	–	–	–	■	–

	Size	Assembly axis EGSC-BS; EGSS-BS			
		25	32	45	60
Base axis	25	■	–	–	–
EGSC-BS;	32	–	■	–	–
EGSS-BS	45	–	–	■	–
	60	–	–	–	■

With adapter kit EHAA-D-L2

- Mounting option: base axis with the same size assembly axis
- Mounting option: base axis with height adjustment for one-size-down assembly axis
- When motors are mounted using parallel kits, this may lead to interfering contours. In this case, the adapter plate is required for height compensation

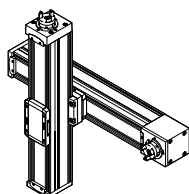
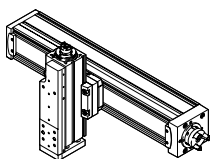
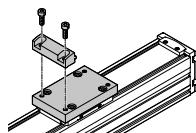

With direct mounting

- Mounting option: base axis with the same size assembly axis

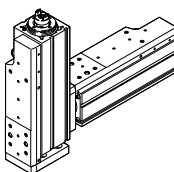

Type codes

001	Series
ELGC	Gantry axis

002	Drive system
BS	Ball screw drive

003	Guide
KF	Recirculating ball bearing guide

004	Size
32	32
45	45
60	60
80	80

005	Stroke
100	100
200	200
300	300
400	400
500	500
600	600
800	800
1000	1000

006	Spindle pitch
8P	8 mm
10P	10 mm
12P	12 mm
16P	16 mm

Peripherals overview

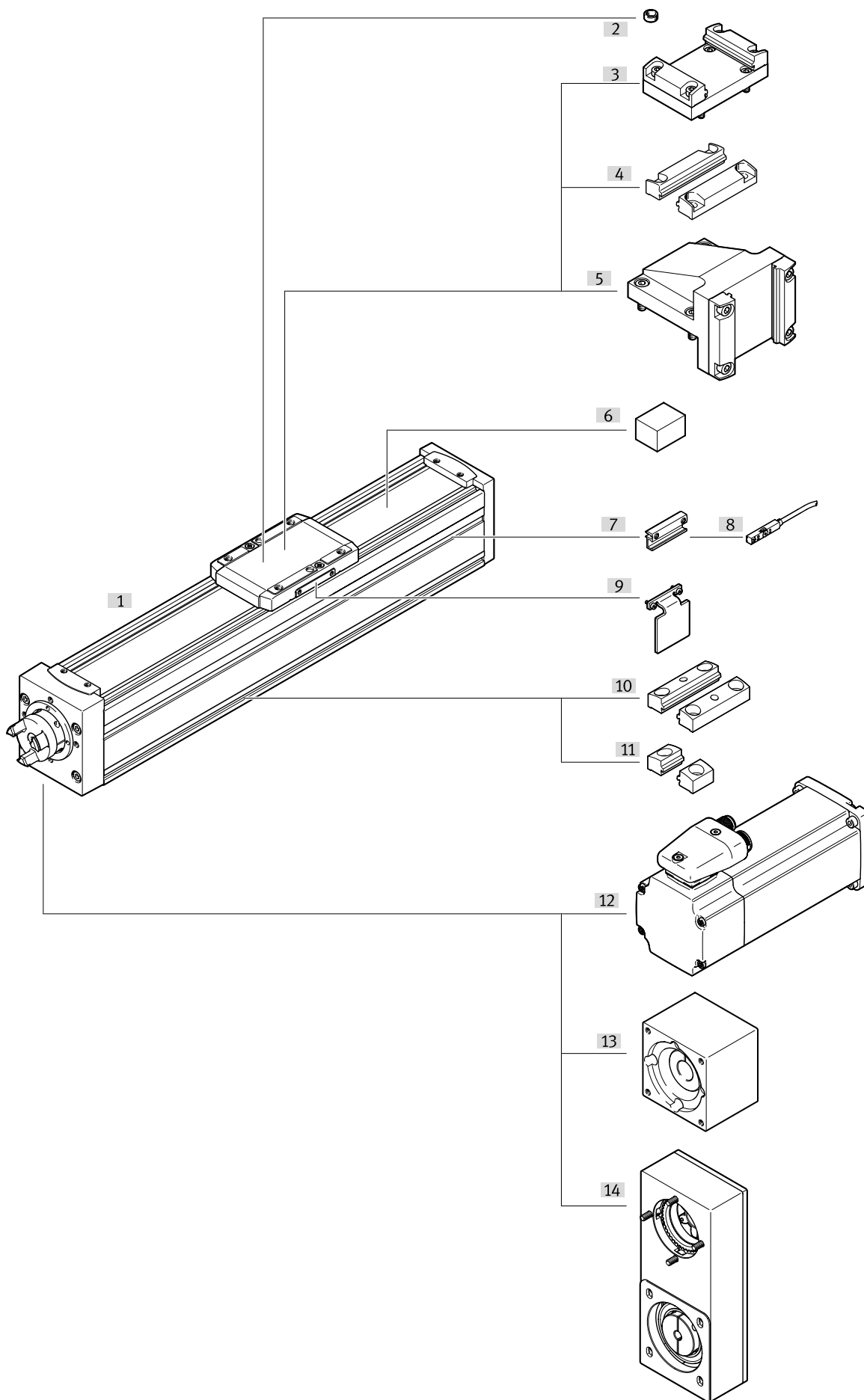

Peripherals overview

Accessories			
Type	Description		→ Page/Internet
[1] Spindle axis ELGC-BS-KF	Electric drive		8
[2] Centring pin/sleeve ZBS/ZBH	For centring loads and attachments on the slide		27
[3] Adapter kit EHAA-D-L2	<ul style="list-style-type: none"> For axis/axis mounting with adapter plate Mounting option: base axis with same size or one-size-down assembly axis (→ page 1) When motors are mounted using parallel kits, this may lead to interfering contours. In this case, the adapter plate is required for height compensation (download CAD data → www.festo.com) 		24
[4] Profile mounting EAHF-L2-...-P-D...	<ul style="list-style-type: none"> For axis/axis mounting without adapter plate Mounting option: base axis with one-size-down assembly axis (→ page 4) 		23
[5] Angle kit EHAA-D-L2-...-AP	For mounting one-size-down vertical axes (assembly axes) on base axes with mounting position "slide at top" (→ page 4)		25
[6] Clamping element EADT-S-L5-32	Tool for retensioning the cover strip		27
[7] Sensor bracket EAPM-L2-SH	For mounting the proximity switches on the axis. The proximity switches can only be mounted using the sensor bracket		26
[8] Proximity switches SIES-8M	Inductive proximity switches, for T-slot		27
Proximity switches SMT-8M	Magnetic proximity switches, for T-slot		27
[9] Switch lug EAPM-L2-...-SLS	For sensing the slide position in conjunction with inductive proximity switches SIES-8M		26
[10] Profile mounting EAHF-L2-...-P	For mounting the axis on the side of the profile. The profile mounting can be attached to the mounting surface using the drilled hole in the centre		22
[11] Profile mounting EAHF-L2-...-P-S	For mounting the axis on the side of the profile		21
[12] Motor EMME-AS, EMMS-ST	Motors specially matched to the axis, with or without brake		19
[13] Axial kit EAMM-A	For axial motor mounting		19
[14] Parallel kit EAMM-U	For parallel motor mounting		20

Sealing air connection



Air is exchanged between the interior of the cylinder and the environment via a sealing air connection. This prevents negative pressure or overpressure arising in the interior of the cylinder.



Additional functions of the connection:

- Application of slight negative pressure prevents emission of particles
- Application of slight overpressure prevents immission of particles

Suitable push-in fittings → page 27

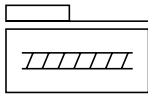
Data sheet



-  - Size
32 ... 80
-  - Stroke length
100 ... 1000 mm
-  - www.festo.com



General technical data				
Size	32	45	60	80
Design	Electromechanical axis with ball screw drive			
Guide	Recirculating ball bearing guide			
Mounting position	Any			
Working stroke [mm]	100, 200, 300, 400, 500, 600, 800	100, 200, 300, 400, 500, 600, 800	100, 200, 300, 400, 500, 600, 800	100, 200, 300, 400, 500, 600, 800, 1000
Max. feed force F_x [N]	40	100	200	350
No-load torque at [Nm]	0.02	0.032	0.042	0.095
Low travel speed [m/s]	0.05	0.05	0.05	0.05
No-load torque at [Nm]	0.04	0.12	0.25	0.40
Max. travel speed [m/s]	0.6	0.6	0.8	1
Max. radial force ¹⁾ [N]	75	180	230	400
Max. rotational speed ²⁾ [rpm]	4500	3600	4000	3750
Max. acceleration [m/s ²]	15			
Repetition accuracy [mm]	±0.015	±0.015	±0.01	±0.01
Reversing backlash [mm]	≤ 0.15			
Position sensing	Magneto-resistive, inductive			

- 1) At the driving shaft
2) Rotational speed and travel speed are stroke-dependent

Operating and environmental conditions	
Ambient temperature ¹⁾ [°C]	0 ... +50
Degree of protection	IP40
Duty cycle [%]	100
Maintenance interval	Life-time lubrication

- 1) Note operating range of proximity switches

Weight [g]				
Size	32	45	60	80
Basic weight with 0 mm stroke ¹⁾	296	724	1682	2942
Additional weight per 10 mm stroke	18	36	51	88
Moving mass	83	220	525	978

- 1) Incl. slide

Data sheet

Spindle					
Size		32	45	60	80
Diameter	[mm]	8	10	12	16
Pitch	[mm/rev]	8	10	12	16
Mass moment of inertia					
Size		32	45	60	80
J_0	[kg mm ²]	0.274	0.820	2.235	7.856
J_H per metre stroke	[kg mm ² /m]	2.218	5.056	10.779	35.257
J_L per kg payload	[kg mm ² /kg]	1.621	2.533	3.648	6.485

The mass moment of inertia J_{rot} of the rotating parts of the axis is calculated as follows:

$$J_{rot} = J_0 + J_H \times \text{working stroke [m]}$$

Homing

Homing can be carried out in two ways:

- Against a fixed stop
- Using a reference switch

The following values must be observed:

Size		32	45	60	80
Max. impact energy	[J]	0.25×10^{-3}	0.5×10^{-3}	1×10^{-3}	2×10^{-3}
At max. homing speed	[m/s]	0.01			

Materials

Sectional view

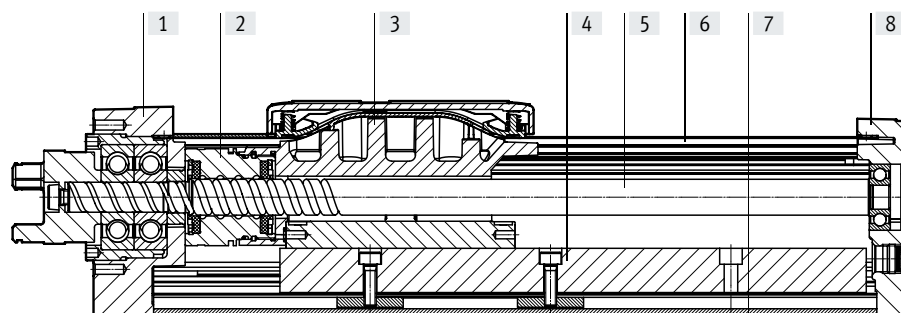

Axis	
[1] Drive cover	Painted die-cast aluminium
[2] Spindle nut	Steel
[3] Slide	Die-cast aluminium
[4] Guide	Steel
[5] Spindle	Steel
[6] Cover strip	High-alloy stainless steel
[7] Profile	Anodised wrought aluminium alloy
[8] End cap	Painted die-cast aluminium
Note on materials	RoHS-compliant
	Contains paint-wetting impairment substances

Data sheet

Characteristic load values

The indicated forces and torques refer to the centre of the guide. The point of application of force is the point where the centre of the guide and the longitudinal centre of the slide intersect. These values must not be exceeded during dynamic operation. Special attention must be paid to the deceleration phase.

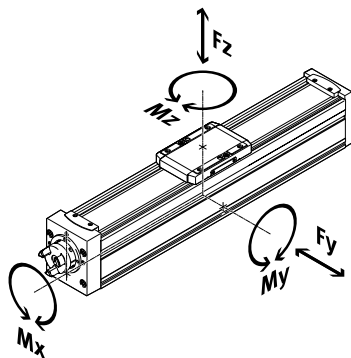

Distance from the slide surface to the centre of the guide

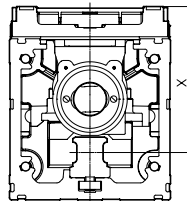

Max. permissible forces and torques on the slide (strength limits)					
Size		32	45	60	80
$F_{y_{max}}$	[N]	150	300	600	900
$F_{z_{max}}$	[N]	300	600	1800	2700
$M_{x_{max}}$	[Nm]	1.3	5.5	29.1	59.8
$M_{y_{max}}$	[Nm]	1.1	4.7	31.8	56.2
$M_{z_{max}}$	[Nm]	1.1	4.7	31.8	56.2

Distance from the slide surface to the centre of the guide					
Size		32	45	60	80
Dimension x	[mm]	31.4	42.8	54.6	72.5

Max. permissible forces and torques for the guide calculation, for a service life of 5000 km or 5×10^6 cycles					
Size		32	45	60	80
$F_{y_{max}}$	[N]	356	880	3641	5543
$F_{z_{max}}$	[N]	356	880	3641	5543
$M_{x_{max}}$	[Nm]	1.3	5.5	29.1	59.8
$M_{y_{max}}$	[Nm]	1.1	4.7	31.8	56.2
$M_{z_{max}}$	[Nm]	1.1	4.7	31.8	56.2

Note

For a guide system to have a service life of 5000 km, the load comparison factor must have a value of $f_v \leq 1$, based on the maximum permissible forces and torques for a service life of 5000 km.

This formula can be used to calculate a guide value.

The engineering software "Electric Motion Sizing" is available for more precise calculations → www.festo.com/x/electric-motion-sizing

If the axis is subjected to two or more of the indicated forces and torques simultaneously, the following equation must be satisfied in addition to the indicated maximum loads:

Calculating the load comparison factor:

$$f_v = \frac{|F_{y1}|}{F_{y2}} + \frac{|F_{z1}|}{F_{z2}} + \frac{|M_{x1}|}{M_{x2}} + \frac{|M_{y1}|}{M_{y2}} + \frac{|M_{z1}|}{M_{z2}} \leq 1$$

F_1/M_1 = dynamic value

F_2/M_2 = maximum value

Data sheet

Calculating the service life

The service life of the guide depends on the load. To be able to make a statement as to the service life of the guide, the graph below plots the load comparison factor f_v against the service life.

These values are only theoretical. You must consult your local Festo contact for a load comparison factor f_v greater than 1.

Load comparison factor f_v as a function of service life l

Example:

A user wants to move an x kg load. Using the formula (→ page 10) gives a value of 1.5 for the load comparison factor f_v . According to the graph, the guide would have a service life of approx. 1500 km. Reducing the acceleration reduces the M_y and M_z values. A load comparison factor f_v of 1 now gives a service life of 5000 km.

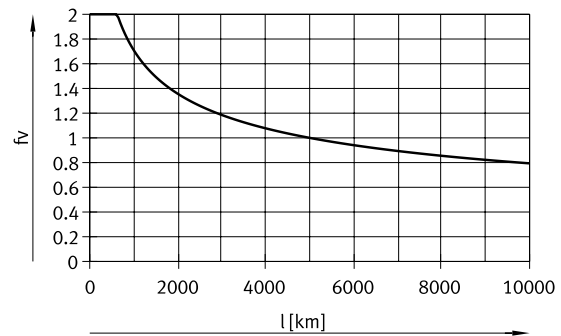

Comparison of the characteristic load values for 5000 km with dynamic forces and torques of recirculating ball bearing guides

The characteristic load values of the bearing guides are standardised to ISO and JIS using dynamic and static forces and torques. These forces and torques are based on an expected service life of the guide system of 100 km according to ISO or 50 km according to JIS.

As the characteristic load values are dependent on the service life, the maximum permissible forces and torques for a 5000 km service life cannot be compared with the dynamic forces and torques of bearing guides to ISO/JIS.

To make it easier to compare the guide capacity of linear axes ELGC with bearing guides, the table below lists the theoretically permissible forces and torques for a calculated service life of 100 km. This corresponds to the dynamic forces and torques to ISO.

These 100 km values have been calculated mathematically and are only to be used for comparing with dynamic forces and torques to ISO. The drives must not be loaded with these characteristic values as this could damage the axes.

Max. permissible forces and torques for a theoretical service life of 100 km (from a guide perspective only)

Size		32	45	60	80
$F_{y_{max}}$	[N]	1310	3240	13400	20400
$F_{z_{max}}$	[N]	1310	3240	13400	20400
$M_{x_{max}}$	[Nm]	5	20	107	220
$M_{y_{max}}$	[Nm]	4	17	117	207
$M_{z_{max}}$	[Nm]	4	17	117	207

Data sheet

Speed v as a function of working stroke l

Size 32

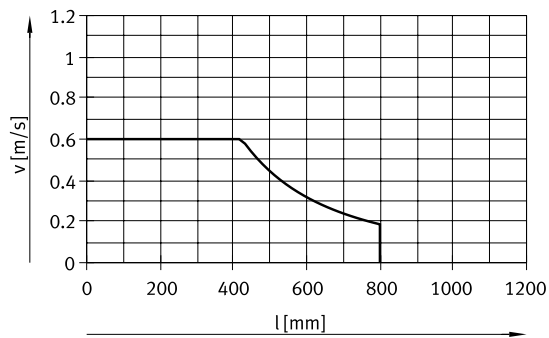

Size 45

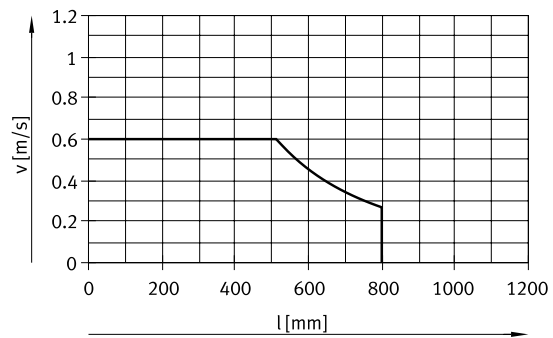

Size 60

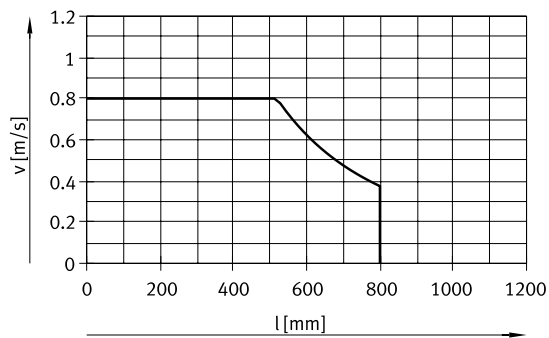

Size 80

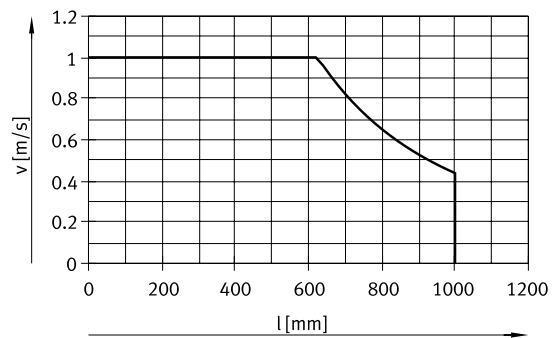

Feed force F as a function of input torque M

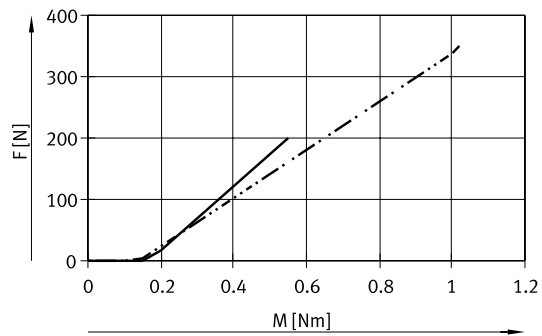
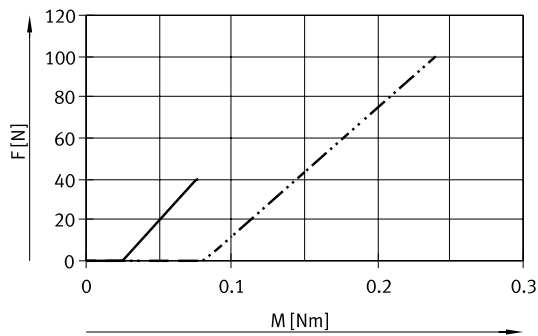

— ELGC-BS-KF-32
 - · - · - · ELGC-BS-KF-45

— ELGC-BS-KF-60
 - · - · - · ELGC-BS-KF-80

Data sheet

Feed force F as a function of service life l

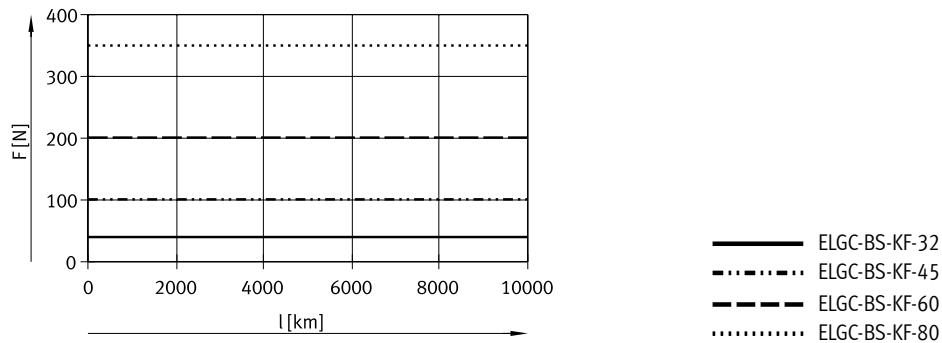

2nd moments of area

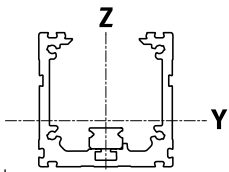

Size		32	45	60	80
I_y	[mm ⁴]	38×10^3	140×10^3	441×10^3	1.37×10^6
I_z	[mm ⁴]	45×10^3	170×10^3	542×10^3	1.66×10^6

Recommended deflection limits

Adherence to the following deflection limits is recommended so as not to impair the functionality of the axes. Greater deformation can result in increased friction, greater wear and reduced service life.

Size	Dynamic deflection (moving load)	Static deflection (stationary load)
32 ... 80	0.05% of the axis length, max. 0.5 mm	0.1% of the axis length

Data sheet

Dimensions

Download CAD data → www.festo.com

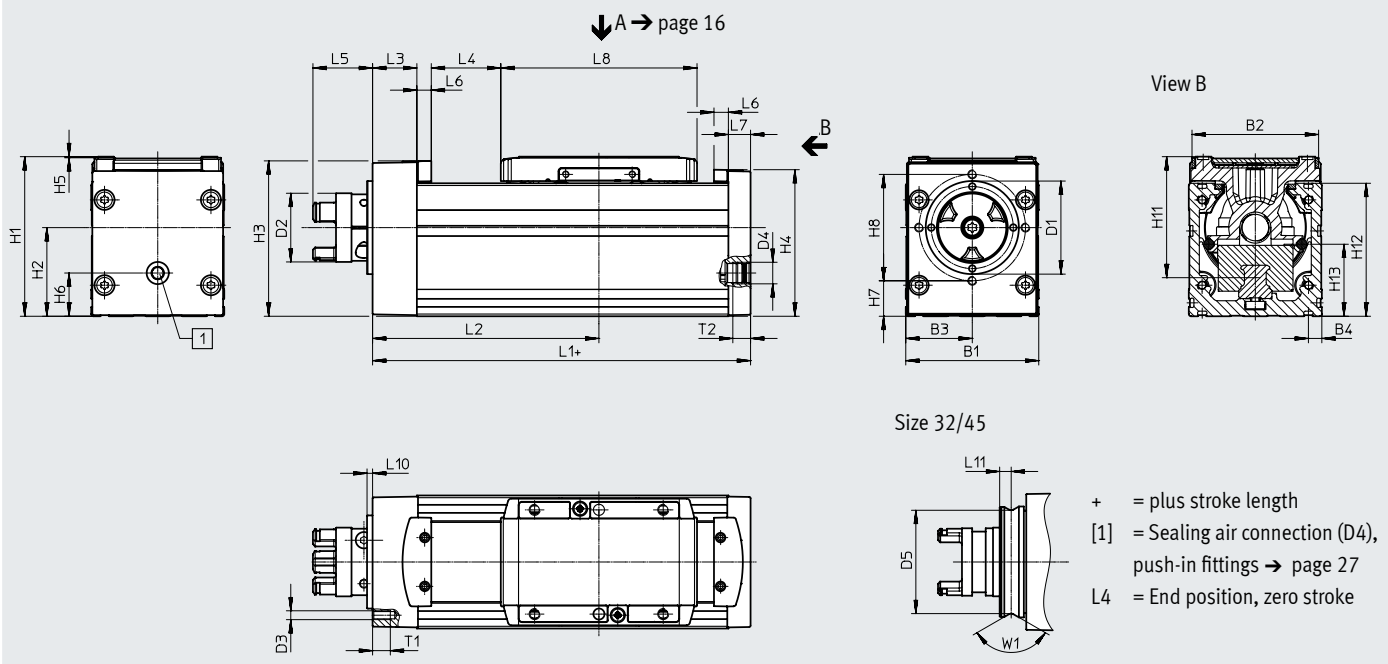

Size	B1	B2	B3	B4	D1 ∅	D2 ¹⁾ ∅	D3	D4	D5 ∅	H1	H2
32	32	29.6	16	4.9	25	15.5	-	M5	23	38.5	20
45	45	42.6	22.5	6.1	32	16.3	-	G1/8	29.6	54	27.9
60	60	57.1	30	6.1	42	31.4	M4	G1/8	-	72	40
80	80	77.1	40	6.1	46	31.4	M6	G1/8	-	96	50

Size	H3	H4	H5	H6	H7	H8	H11	H12	H13	L1	L2 min.
32	36.3	35.6	0.3	8	-	-	31.4	32	13.7	104.5	57.9
45	50.8	49.6	0.5	12.5	-	-	42.8	45	18.5	134.3	79.7
60	70.1	66.1	0.5	19.5	16	48	54.6	60	32.5	170.5	102.1
80	90.6	88.1	0.5	20	17.5	65	72.5	80	41.5	198.5	119.6

Size	L3	L4	L5	L6	L7	L8	L10	L11	T1	T2	W1
32	10.5	13.4	19.9	4.5	5	59	6	2.6	-	5.5	120°
45	14.8	24.6	19.9	6.5	7	67.5	6	2.9	-	8	90°
60	20	31.4	26.9	6.5	10	88.5	2.5	-	8	8	-
80	21	39.1	25.9	6.5	12	106	2.5	-	15	8	-

1) Coupling diameter or interference diameter of locking screw

Data sheet

Dimensions

Download CAD data → www.festo.com

Profile

Size 32

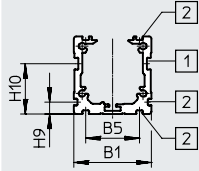

Size 45

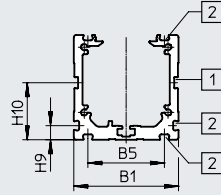

Size 60

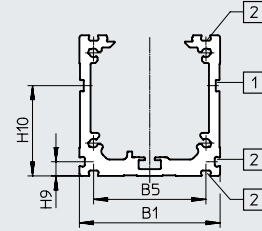

Size 80

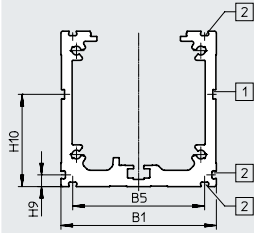

[1] = Slot for sensor bracket
[2] = mounting slot

Size	B1	B5	H9	H10
32	32	22.2	4.9	20.8
45	45	32.9	6.1	24.5
60	60	47.9	6.1	38.5
80	80	67.9	6.1	47.5

Data sheet

Dimensions

Download CAD data → www.festo.com

Slide
Size 32

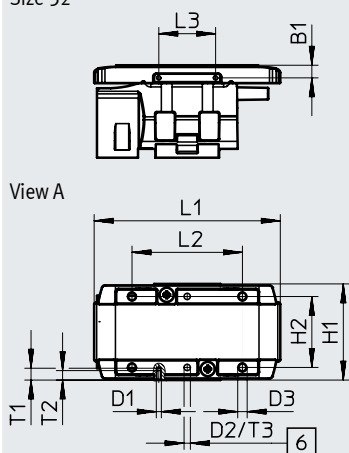

Size 45

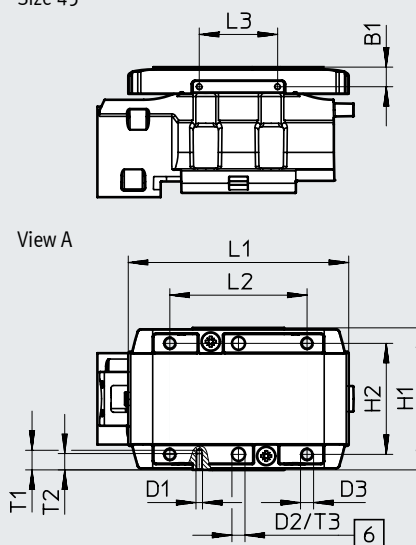

[6] Drill hole for centring pin ZBS

Size	B1	D1	D2 ∅ H8	D3	H1	H2 ±0.1 For D2 ±0.03
32	4 ±0.1	M1.6	2	M3	30.5	22.5
45	6	M2	4	M4	43.5	34

Size	L1	L2	L3	T1	T2	T3	T4 ¹⁾
		±0.1	±0.1			+0.1	
32	59	35	18	3.8	3	3.1	4 ... 5
45	67.5	42	24	6	5	3.1	6 ... 7.5

1) Recommended screw-in depth

Data sheet

Dimensions

Download CAD data → www.festo.com

Slide

Size 60

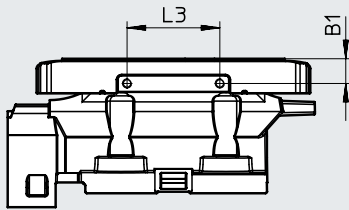

Size 80

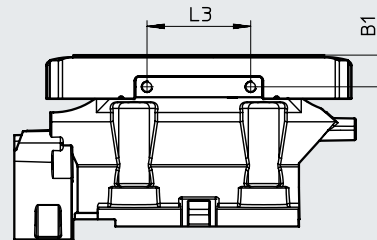

View A

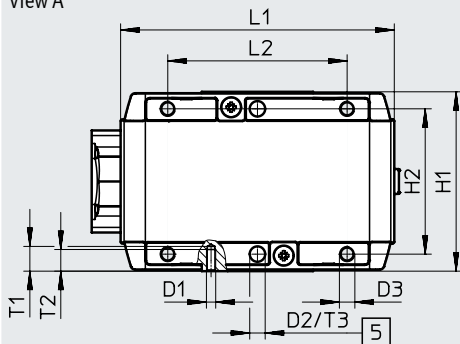

View A

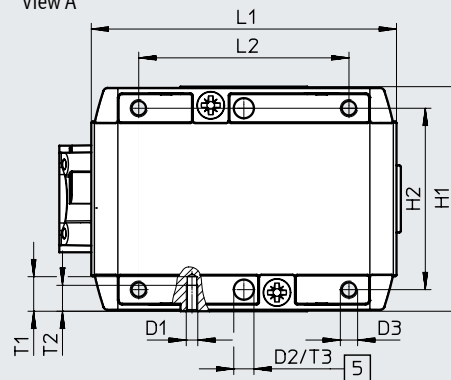

[5] Drilled hole for centring pin ZBH

Size	B1 ±0.1	D1	D2 ∅ H8	D3	H1 ±0.1	H2 ±0.1 For D2 ±0.03
60	8	M3	5	M5	58	47
80	11	M4	7	M6	78	63

Size	L1	L2 ±0.1	L3 ±0.1	T1	T2	T3 +0.1	T4 ¹⁾
60	88.5	58	30	9	7	1.3	8.5 ... 10
80	106	73	36	12	9	1.6	11 ... 14

1) Recommended screw-in depth

Data sheet

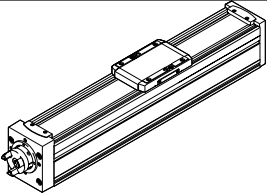
Ordering data	Size	Pitch [mm/rev]	Stroke [mm]	Part no.	Type
	32	8	100	8061477	ELGC-BS-KF-32-100-8P
			200	8061478	ELGC-BS-KF-32-200-8P
			300	8061479	ELGC-BS-KF-32-300-8P
			400	8061480	ELGC-BS-KF-32-400-8P
			500	8061481	ELGC-BS-KF-32-500-8P
			600	8061482	ELGC-BS-KF-32-600-8P
			800	8061483	ELGC-BS-KF-32-800-8P
	45	10	100	8061484	ELGC-BS-KF-45-100-10P
			200	8061485	ELGC-BS-KF-45-200-10P
			300	8061486	ELGC-BS-KF-45-300-10P
			400	8061487	ELGC-BS-KF-45-400-10P
			500	8061488	ELGC-BS-KF-45-500-10P
			600	8061489	ELGC-BS-KF-45-600-10P
			800	8061490	ELGC-BS-KF-45-800-10P
	60	12	100	8061491	ELGC-BS-KF-60-100-12P
			200	8061492	ELGC-BS-KF-60-200-12P
			300	8061493	ELGC-BS-KF-60-300-12P
			400	8061494	ELGC-BS-KF-60-400-12P
			500	8061495	ELGC-BS-KF-60-500-12P
			600	8061496	ELGC-BS-KF-60-600-12P
			800	8061497	ELGC-BS-KF-60-800-12P
	80	16	100	8061498	ELGC-BS-KF-80-100-16P
			200	8061499	ELGC-BS-KF-80-200-16P
			300	8061500	ELGC-BS-KF-80-300-16P
			400	8061501	ELGC-BS-KF-80-400-16P
			500	8061502	ELGC-BS-KF-80-500-16P
			600	8061503	ELGC-BS-KF-80-600-16P
			800	8061504	ELGC-BS-KF-80-800-16P
1000			8061505	ELGC-BS-KF-80-1000-16P	

Accessories

 -  - **Note**

Depending on the combination of motor and drive, it may not be possible to reach the maximum feed force of the drive.

When using parallel kits, the no-load driving torque of the particular kit must be taken into consideration.

Permissible axis/motor combinations with axial kit – Without gear unit

Data sheets → Internet: eamm-a

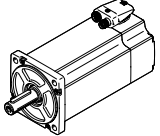
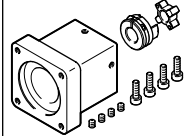
Motor ¹⁾	Axial kit	
		• Kits for third-party motors → Internet: eamm-a
Type	Part no.	Type
ELGC-BS-KF-32		
With servo motor		
EMME-AS-40-...	4491059	EAMM-A-V25-40P
With stepper motor		
EMMS-ST-42-...	4582608	EAMM-A-V25-42A
ELGC-BS-KF-45		
With servo motor		
EMME-AS-40-...	4595742	EAMM-A-V32-40P
EMME-AS-60-...	4608750	EAMM-A-V32-60P
With stepper motor		
EMMS-ST-42-...	4281142	EAMM-A-V32-42A
EMMS-ST-57-...	4597016	EAMM-A-V32-57A
ELGC-BS-KF-60		
With servo motor		
EMMT-AS-60-...	4133487	EAMM-A-T42-60P
EMME-AS-60-...	4133487	EAMM-A-T42-60P
EMMT-AS-80-...	4623788	EAMM-A-T42-80P
EMME-AS-80-...	4623788	EAMM-A-T42-80P
With stepper motor		
EMMS-ST-57-...	4327034	EAMM-A-T42-57A
EMMS-ST-87-...	4610008	EAMM-A-T42-87A
ELGC-BS-KF-80		
With servo motor		
EMMT-AS-60-...	4824833	EAMM-A-T46-60P
EMME-AS-60-...	4824833	EAMM-A-T46-60P
EMMT-AS-80-...	4624170	EAMM-A-T46-80P
EMME-AS-80-...	4624170	EAMM-A-T46-80P
EMMT-AS-100-...	4624227	EAMM-A-T46-100A
EMME-AS-100-...	4624227	EAMM-A-T46-100A
With stepper motor		
EMMS-ST-87-...	4048771	EAMM-A-T46-87A

1) The input torque must not exceed the max. permissible transferable torque of the axial kit.

Accessories

Data sheets → Internet: eamm-u

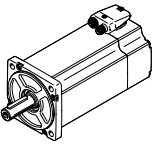
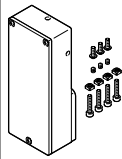
Permissible axis/motor combinations with parallel kit	
Motor/gear unit ¹⁾	Parallel kit
	 <ul style="list-style-type: none"> • The kit can be mounted in all directions • Kits for third-party motors → Internet: eamm-u
Type	Part no. Type
ELGC-BS-KF-32	
With servo motor	
EMME-AS-40-...	4782056 EAMM-U-45-V25-40P-63
With stepper motor	
EMMS-ST-42-...	4825645 EAMM-U-45-V25-42A-63
ELGC-BS-KF-45	
With servo motor	
EMME-AS-40-...	4718297 EAMM-U-45-V32-40P-63
With stepper motor	
EMMS-ST-42-...	4280674 EAMM-U-45-V32-42A-63
ELGC-BS-KF-60	
With servo motor	
EMMT-AS-60-...	4784301 EAMM-U-65-T42-60P-87
EMME-AS-60-...	4784301 EAMM-U-65-T42-60P-87
With stepper motor	
EMMS-ST-57-...	4331535 EAMM-U-65-T42-57A-87
ELGC-BS-KF-80	
With servo motor	
EMMT-AS-60-...	4824069 EAMM-U-87-T46-60P-114
EMME-AS-60-...	4824069 EAMM-U-87-T46-60P-114
EMMT-AS-80-...	4822696 EAMM-U-87-T46-80P-114
EMME-AS-80-...	4822696 EAMM-U-87-T46-80P-114
With stepper motor	
EMMS-ST-87-...	4819278 EAMM-U-87-T46-87A-114

1) The input torque must not exceed the max. permissible transferable torque of the parallel kit.

Accessories

Profile mounting EAHF-L2-...-P-S

Material:

Anodised wrought aluminium alloy

RoHS-compliant

- For mounting the axis on the side of the profile

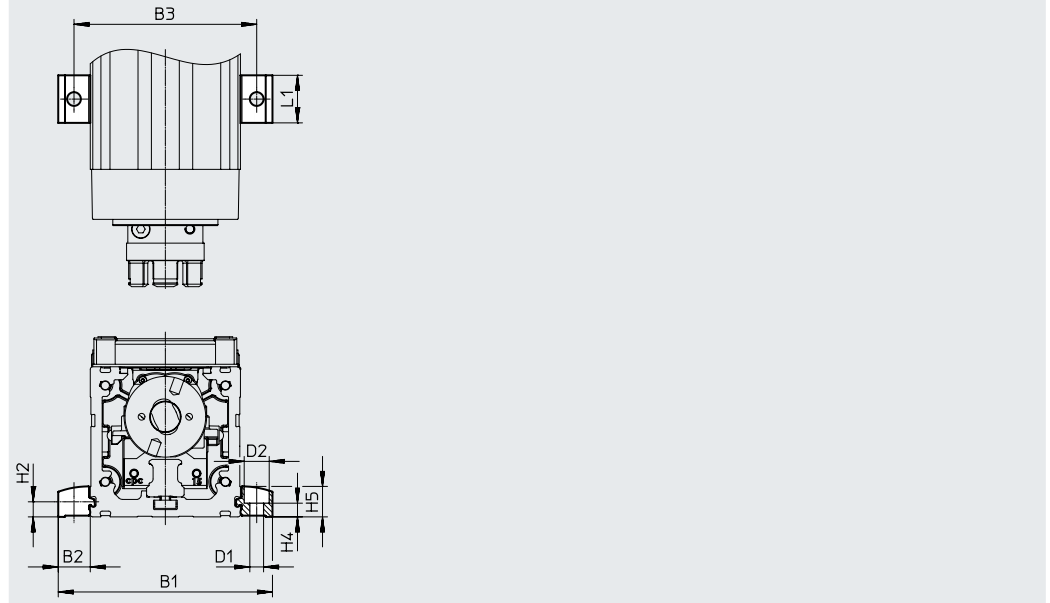
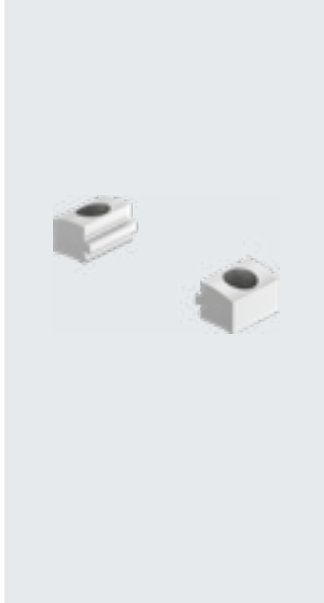

Dimensions and ordering data

For size	B1	B2	B3	D1 ∅ H13	D2 ∅ H13	H2
32	51.4	9.7	42	4.5	8	4.9
45	70.6	12.8	58	5.5	10	6.1
60	85.6	12.8	73	5.5	10	6.1
80	105.6	12.8	93	5.5	10	6.1

For size	H4 ±0.1	H5	L1	Weight [g]	Part no.	Type
32	4.2	9	19	4	5183153	EAHF-L2-25-P-S
45	5.5	12.2	19	6	5184133	EAHF-L2-45-P-S
60	5.5	12.2	19	6	5184133	EAHF-L2-45-P-S
80	5.5	12.2	19	6	5184133	EAHF-L2-45-P-S

Accessories

Profile mounting EAHF-L2-...-P

Material:

Anodised wrought aluminium alloy

RoHS-compliant

- For mounting the axis on the side of the profile.

The profile mounting can be attached to the mounting surface using the drill hole in the centre.

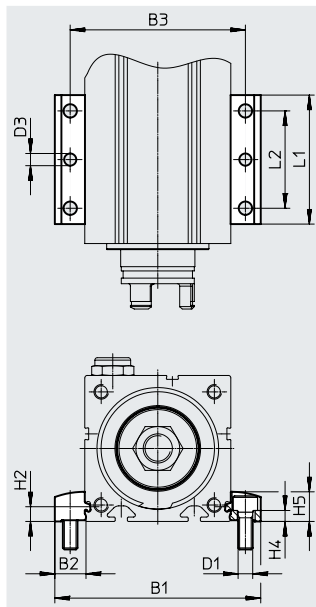

Dimensions and ordering data

For size	B1	B2	B3	D1 ∅ H13	D2 ∅ H13	D3 ∅	H2
32	51.4	9.7	42	4.5	8	4	4.9
45	70.6	12.8	58	5.5	10	5	6.1
60	85.6	12.8	73	5.5	10	5	6.1
80	105.6	12.8	93	5.5	10	5	6.1

For size	H4 ±0.1	H5	L1	L2	Weight [g]	Part no.	Type
32	4.2	9	53	40	19	4835684	EAHF-L2-25-P
45	5.5	12.2	53	40	35	4835728	EAHF-L2-45-P
60	5.5	12.2	53	40	35	4835728	EAHF-L2-45-P
80	5.5	12.2	53	40	35	4835728	EAHF-L2-45-P

Accessories

Profile mounting EAHF-L2-...-P-D...

Material:

Anodised wrought aluminium alloy

RoHS-compliant

- For axis/axis mounting without adapter plate
- Mounting option: base axis with one-size-down assembly axis (→ page 4)

Combination matrix		[2] Assembly axis ELGC-BS/-TB; ELFC; EGSC-BS			
	Size	25	32	45	60
[1] Base axis ELGC-BS/-TB; ELFC	32	4759753	-	-	-
	45	-	4759748	-	-
	60	-	-	4759739	-
	80	-	-	-	4759726

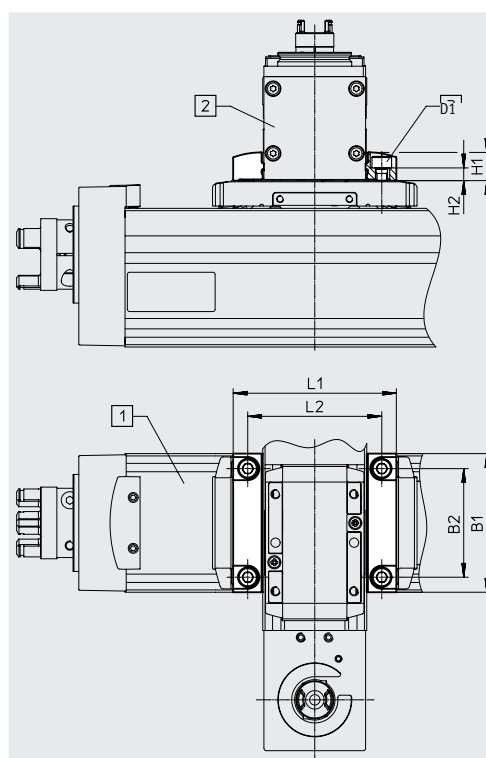

[1] Base axis

[2] Assembly axis

Dimensions and ordering data				
For combination (size)	B1	B2	D1	H1
32/25	32	22.5	M3	9
45/32	45	34	M4	9
60/45	60	47	M5	12.2
80/60	78	63	M6	12.2

For combination (size)	H2 ±0.1	L1	L2	Weight [g]	Part no.	Type
32/25	5.1	44.4	35	16	4759753	EAHF-L2-25-P-D1
45/32	3.7	51.4	42	24	4759748	EAHF-L2-25-P-D2
60/45	5.5	70.6	58	56	4759739	EAHF-L2-45-P-D3
80/60	4.5	85.6	73	77	4759726	EAHF-L2-45-P-D4

Accessories

Adapter kit EHAA-D-L2

Material:

Anodised wrought aluminium alloy

RoHS-compliant

- For axis/axis mounting with adapter plate
- Mounting option: base axis with same size or one-size-down assembly axis (→ page 1)
- When motors are mounted using parallel kits, this may lead to interfering contours. In this case, the adapter plate is required for height compensation (download CAD data → www.festo.com)

Combination matrix

		[2] Assembly axis ELGC-BS/-TB; ELFC; EGSC-BS				
Size		25	32	45	60	80
[1] Base axis ELGC-BS/-TB; ELFC	32	8066713		-	-	-
	45	-	8066714		-	-
	60	-	-	8066715		-
	80	-	-	-	8066716	

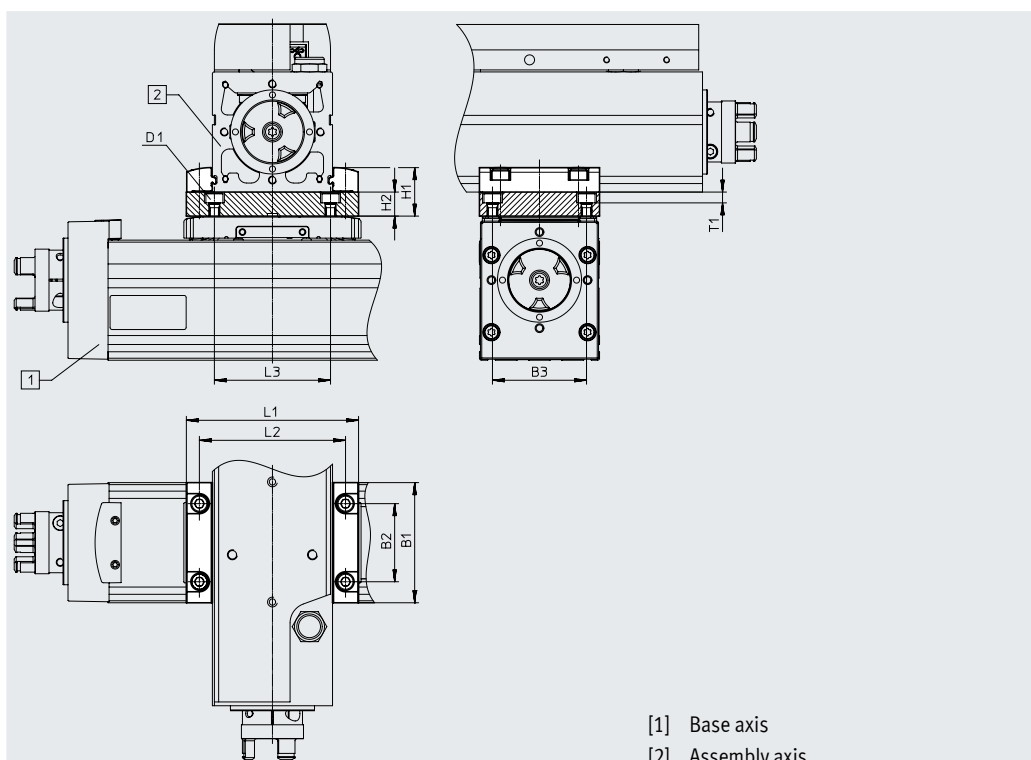

[1] Base axis
[2] Assembly axis

Dimensions and ordering data

For combination (size)	B1	B3 ±0.05	D1	H1	H2	L1	L2	L3	T1	Weight [g]	Part no.	Type
32/25	32	22.5	M3	19	10	44.4	35	35	4.2	60	8066713	EHAA-D-L2-32-L2-32
45/32	45	34	M4	19	10	51.4	42	42	5.4	136	8066714	EHAA-D-L2-45-L2-45
60/45	60	47	M5	24.2	12	70.6	58	58	5.4	205	8066715	EHAA-D-L2-60-L2-60
80/60	78	63	M6	24.2	12	85.6	73	73	6.4	315	8066716	EHAA-D-L2-80-L2-80

For combination (size)	B1	B2	B3 ±0.05	D1	H1	H2	L1	L2	L3	T1	Weight [g]	Part no.	Type
32/32	32	14.5	22.5	M3	19	10	52	42	35	4.2	60	8066713	EHAA-D-L2-32-L2-32
45/45	45	32	34	M4	22.2	10	71	58	42	5.4	136	8066714	EHAA-D-L2-45-L2-45
60/60	60	39	47	M5	24.2	12	86	73	58	5.4	205	8066715	EHAA-D-L2-60-L2-60
80/80	78	63	63	M6	24.2	12	106	93	73	6.4	315	8066716	EHAA-D-L2-80-L2-80

Accessories

Angle kit EHAA-D-L2-...-AP

Material:

Anodised wrought aluminium alloy

RoHS-compliant

- For mounting one-size-down vertical axes (assembly axes) on base axes with mounting position "slide at top" (→ page 4)

Combination matrix		[2] Assembly axis ELGC-BS/-TB; ELFC; EGSC-BS			
	Size	25	32	45	60
[1] Base axis ELGC-BS/-TB; ELFC	32	8066717	-	-	-
	45	-	8066718	-	-
	60	-	-	8066719	-
	80	-	-	-	8066720

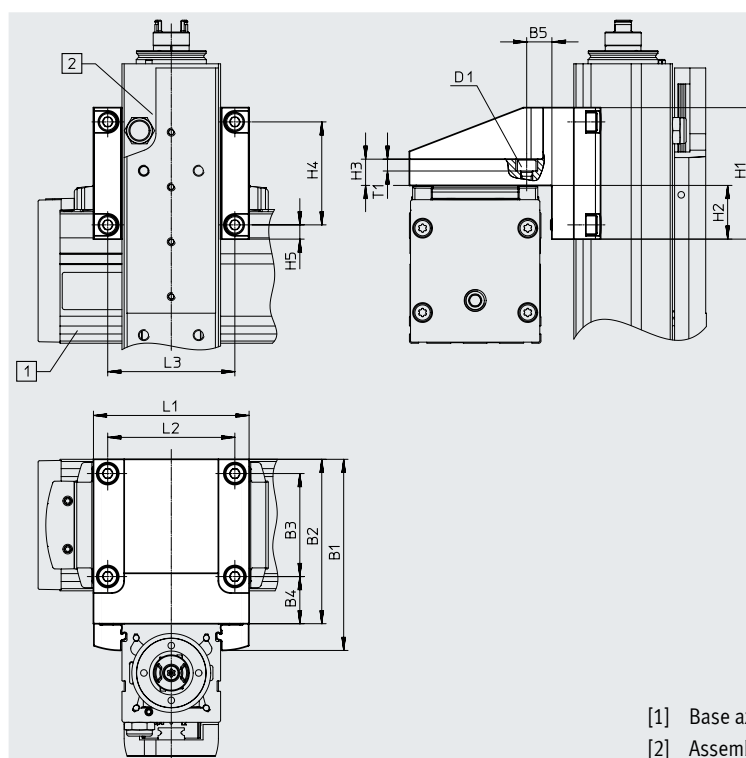

[1] Base axis
[2] Assembly axis

Dimensions and ordering data										
For combination (size)	B1	B2	B3	B4	B5	D1	H1	H2	H3	H4
32/25	53	44	22.5	16.8	8.8	M3	32	11	10	22.5
45/32	69	60	34	20.5	11.5	M4	45	17.5	10	34
60/45	87.2	75	47	21.5	11.5	M5	60	24.5	12	47
80/60	107.2	95	63	23.5	13.5	M6	78	33.5	12	63

For combination (size)	H5	L1	L2	L3	T1	Weight [g]	Part no.	Type
32/25	4.8	45	35	35	4.2	107	8066717	EHAA-D-L2-32-L2-25-AP
45/32	5.5	52	42	42	5.4	222	8066718	EHAA-D-L2-45-L2-32-AP
60/45	6.5	71	58	58	5.4	433	8066719	EHAA-D-L2-60-L2-45-AP
80/60	7.5	86	73	73	6.4	768	8066720	EHAA-D-L2-80-L2-60-AP

Accessories

Switch lug EAPM-L2-SLS

For sensing using inductive proximity switches SIES-8M

Material:
Galvanised steel
RoHS-compliant

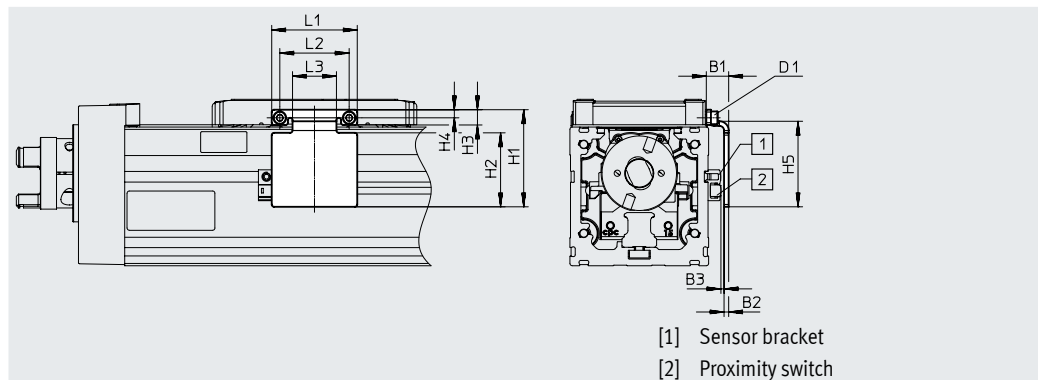

Dimensions and ordering data									
For size	B1	B2	B3	D1	H1 ±0.2	H2	H3	H4	
32	9.2	2	1.0±0.31	M1.6	27	19	4.3	2.5	
45	9.4	2	1.2±0.31	M2	37	28	5.5	3.3	
60	9.7	2	1.3±0.31	M3	37	32	6.6	3.5	
80	9.5	2	1.1±0.32	M4	53.5	42	8.3	4.5	

For size	H5 ±0.2	L1 ±0.2	L2 ±0.15	L3	Weight [g]	Part no.	Type
32	24	22	18	10	10	8067259	EAPM-L2-32-SLS
45	33	30	24	14	18	8067260	EAPM-L2-45-SLS
60	37	42	30	19	27	8067261	EAPM-L2-60-SLS
80	47	44.6	36	23.4	42	8067262	EAPM-L2-80-SLS

Sensor bracket EAPM-L2-SH

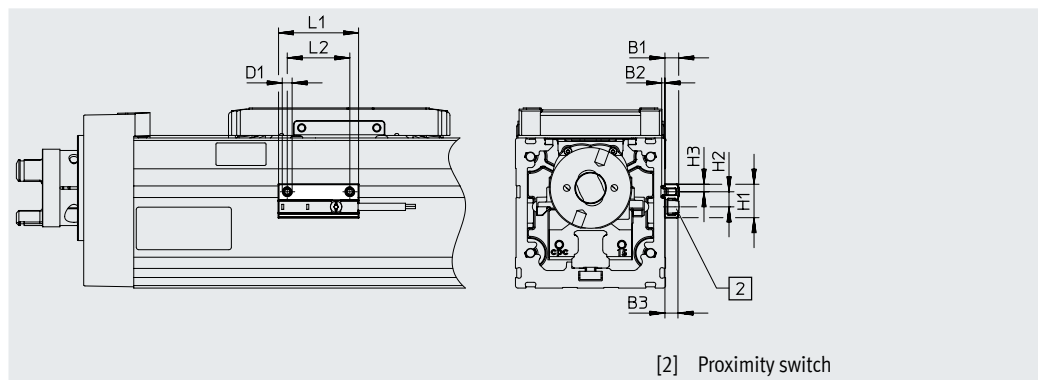

Material:
Anodised wrought aluminium alloy
RoHS-compliant



Dimensions and ordering data						
For size	B1	B2	D1	H1	H2	
32, 45, 60, 80	5.5	1.3	M4	13.4	6	

For size	H3	L1	L2	Weight [g]	Part no.	Type
32, 45, 60, 80	3	32	25	4	4759852	EAPM-L2-SH



Accessories

Ordering data		For size	Description	Part no.	Type	PJ ¹⁾
Centring pin ZBS/centring sleeve ZBH						
	32	For slide		525273	ZBS-2	10
	45			562959	ZBS-4	
	60			189652	ZBH-5	
	80			186717	ZBH-7	
Clamping element EADT						
	32, 45	Tool for retensioning the cover strip		8065818	EADT-S-L5-32	1
	60, 80			8058451	EADT-S-L5-70	
Push-in fitting						
	32	For sealing air connection		133003	QSM-M5-3-I-R	10
	45, 60, 80			133004	QSM-M5-4-I-R	
				186266	QSM-G1/8-4-I	
				186267	QSM-G1/8-6-I	

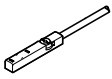
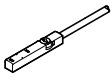
1) Packaging unit

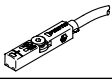
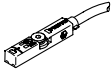
Ordering data – Proximity switches for T-slot, inductive		Switching output	Electrical connection	Cable length [m]	Part no.	Type	Data sheets → Internet: sies
N/O contact							
	Insertable in the slot from above, flush with the cylinder profile	PNP	Cable, 3-wire	7.5	551386	SIES-8M-PS-24V-K-7.5-OE	
			Plug M8x1, 3-pin	0.3	551387	SIES-8M-PS-24V-K-0.3-M8D	
		NPN	Cable, 3-wire	7.5	551396	SIES-8M-NS-24V-K-7.5-OE	
			Plug M8x1, 3-pin	0.3	551397	SIES-8M-NS-24V-K-0.3-M8D	
N/C contact							
	Insertable in the slot from above, flush with the cylinder profile	PNP	Cable, 3-wire	7.5	551391	SIES-8M-PO-24V-K-7.5-OE	
			Plug M8x1, 3-pin	0.3	551392	SIES-8M-PO-24V-K-0.3-M8D	
		NPN	Cable, 3-wire	7.5	551401	SIES-8M-NO-24V-K-7.5-OE	
			Plug M8x1, 3-pin	0.3	551402	SIES-8M-NO-24V-K-0.3-M8D	

Ordering data – Proximity switches for T-slot, magneto-resistive		Switching output	Electrical connection	Cable length [m]	Part no.	Type	Data sheets → Internet: smt
N/O contact							
	Insertable in the slot from above, flush with the cylinder profile, short design	PNP	Cable, 3-wire	2.5	574335	SMT-8M-A-PS-24V-E-2.5-OE	
			Plug M8x1, 3-pin	0.3	574334	SMT-8M-A-PS-24V-E-0.3-M8D	
N/C contact							
	Insertable in the slot from above, flush with the cylinder profile, short design	PNP	Cable, 3-wire	7.5	574340	SMT-8M-A-PO-24V-E-7.5-OE	

Ordering data – Connecting cables		Electrical connection, left	Electrical connection, right	Cable length [m]	Part no.	Type	Data sheets → Internet: nebu
	Straight socket, M8x1, 3-pin		Cable, open end, 3-wire	2.5	541333	NEBU-M8G3-K-2.5-LE3	
				5	541334	NEBU-M8G3-K-5-LE3	
	Angled socket, M8x1, 3-pin		Cable, open end, 3-wire	2.5	541338	NEBU-M8W3-K-2.5-LE3	
				5	541341	NEBU-M8W3-K-5-LE3	